



PT. ALMIK KURNIA BERSAMA

WWW.PTALMIK.COM

PRODUCT LINE UP

TABLE OF CONTENT

03	COMPANY PROFILE
08	OFFICE & SCHOOL EQUIPMENT
29	WORKSHOP EQUIPMENT
40	COLOR PALLETE
41	MIM DIVISION
49	ENGINEERING DIVISION

COMPANY PROFILE



PT. ALMIK KURNIA BERSAMA

PT Almik Kurnia Bersama was established on 28 December 2003, which is a “marketing company” of high quality standard and job order / customized products produced by PT ATMI Solo, PT ATMI IGI Center, and PT ATMI Cikarang. Among the National Manufacturing Industry, ATMI Group have been authorized as professional manufacturer with excellent product quality.

COMPANY PROFILE



PT. ALMIK KURNIA BERSAMA

NIB : 9120009622346

NPWP No: 02.361.275.7-027.000

Akte Pendirian: No. 94 Tanggal 28 Desember 2003
Akte Perubahan: No. 25 Tanggal 29 April 2016

SIUPP: No. 1374/24.1PM.1/31.71/-1.824.27/e/2016
Perdagangan Besar Mesin Peralatan dan Perlengkapan
lainnya

COMPANY PROFILE



PT. ATMI SOLO

ATMI was authorized as a legal entity in 1964, and in 1968 began operating in the field of education and in 1971 ATMI began marketing its products. ATMI's fabrication/workshop continues to grow from year to year with the addition of advanced technology machines such as CAD, CAM, Wire cut, EDM, CNC and expansion of production unit.

PRODUCT QUALITY



Management
System
ISO 9001:2015



www.tuv.com
ID 9108632724

PRODUCTION CERTIFICATE

ISO 9001:2015 certificate from the German TÜV Rheinland Certification institution, as a sign of recognition for successful quality management according to International Standards in the field of Academics and Manufacturing



Steel plate thickness up to 2.8 mm

OUR DIVISION



OFFICE & INDUSTRIAL DIVISION

OFFICE EQUIPMENT
LEARNING EQUIPMENT
WORKSHOP EQUIPMENT
HEAVY DUTY EQUIPMENT



ENGINEERING DIVISION

SPECIAL PURPOSE MACHINE
MOLD & DIES
PRECISION PARTS
INSPECTION JIG
SOLAR PANEL
MACHINE AGENT

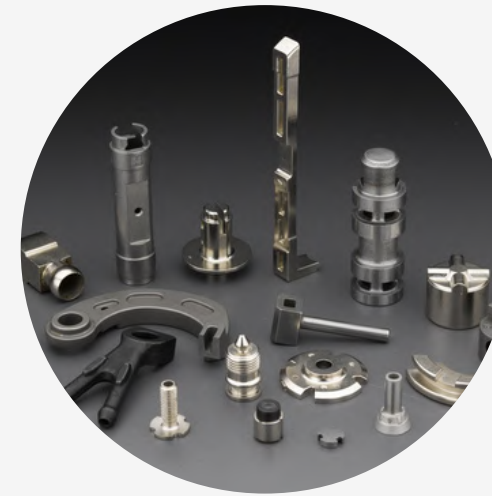

MIM DIVISION

METAL INJECTION MOLDING



HEALTH DIVISION

HOSPITAL EQUIPMENT
PHARMACY
(on progress)



OUR PRODUCTS

WWW.PTALMIK.COM



OUR PRODUCTS

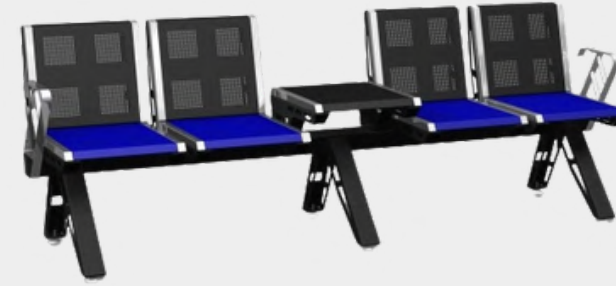

OFFICE & LEARNING EQUIPMENT



PRODUCTS

DESK SERIES

CHAIR SERIES

CABINET & CUPBOARD

MOBILE FILE

LOCKER SERIES



1 05 001



1 05 004 (Optional Cabinet)



1 05 002



1 05 005 (Optional Cabinet)

Spesification

Dimension (mm)	W x D x H
1 05 001	1500 x 800 x 760
1 05 002	1800 x 800 x 760
1 05 003	1800 x 1973 x 670/760
1 05 004	1200 x 750 x 760
1 05 005	1200 x 600 x 750
1 05 006	1500 x 600 x 750

Material

- Steel plate cold-rolled coiled (SPCC - JIS G 3141). Thickness 0.9 - 2.8 mm
- Plywood with HPL / Mega Teak

Features

- Equipped a key with Cam lock type
- Available in several types of pedestal / cabinet
- Power socket

Finishing

Electrostatic Powder Coating



1 05 003



1 05 006 (Optional Cabinet)

DESK SERIES



1 05 028

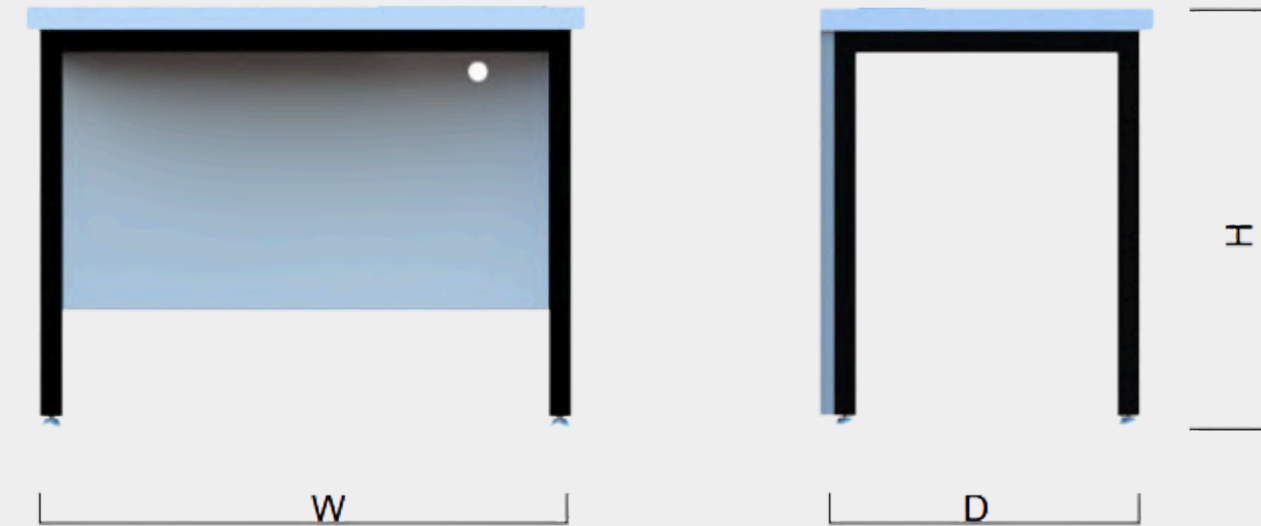

1 05 029



Spesification

Dimension (mm)	W x D x H
1 05 028	1000 x 600 x 750
1 05 029	1200 x 700 x 750
Material	- Steel plate cold-rolled coiled (SPCC - JIS G 3141) Thickness 0.9 mm - Square pipe - Plywood covered by HPL / Mega Teak
Features	- Plastic Foot / Foot Adjuster - Power Socket
Finishing	Electrostatic Powder Coating

DESK SERIES



1 05 010



1 05 012



1 05 014

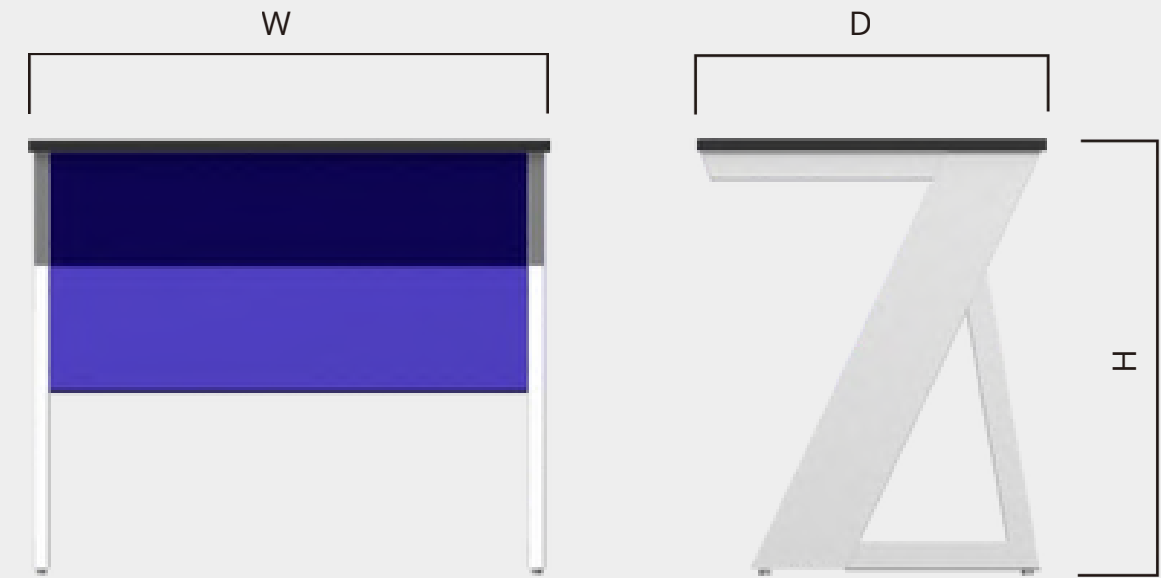

1 05 015



1 05 016



1 05 017

Spesification

Dimension (mm)

W x D x H

1 05 010	700 x 600 x 750
1 05 012	700 x 600 x 750
1 05 014	700 x 500 x 750
1 05 015	700 x 600 x 750
1 05 016	900 x 650 x 750
1 05 017	1200 x 800 x 750

Material

- Steel plate cold-rolled coiled (SPCC - JIS G 3141)
Thickness 0.9 mm
- Plywood covered by HPL / Mega teak

Features

- Plastick Foot / Foot Adjuster
- Poser Socket

Finishing

Electrostatic Powder Coating

DESK SERIES

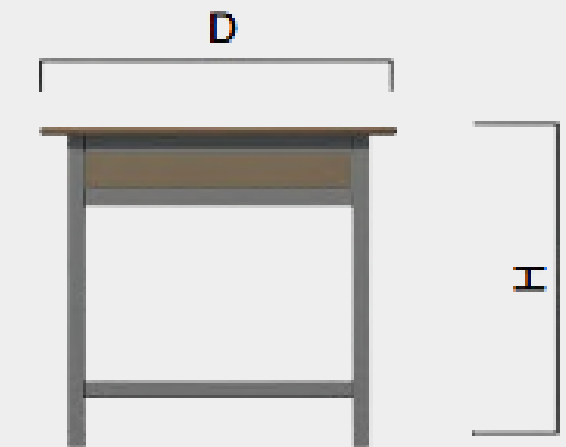
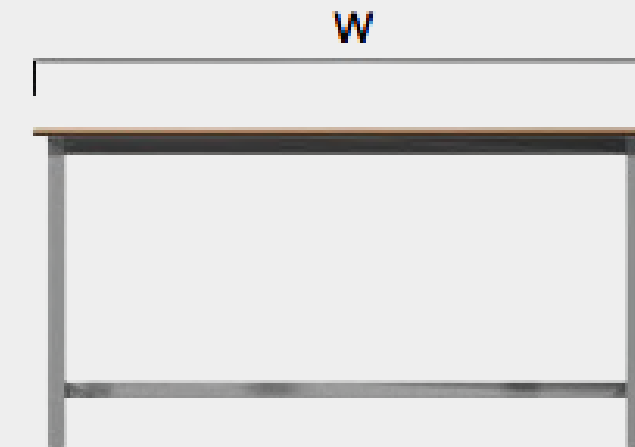

Spesification

Dimension (mm)	W	x	D	x	H
0 05 022	1200	x	600	x	750
0 05 023	1400	x	600	x	750
0 05 025			∅1000	x	750
0 05 026			∅1000	x	1050
0 05 027	1800	x	600	x	700

Material

- Steel plate cold-rolled coiled (SPCC - JIS G 3141)
- Pipe
- Multiplex covered by HPL / Mega teak

Finishing

Electrostatic Powder Coating

DESK SERIES



1 05 030



1 05 031



1 05 032

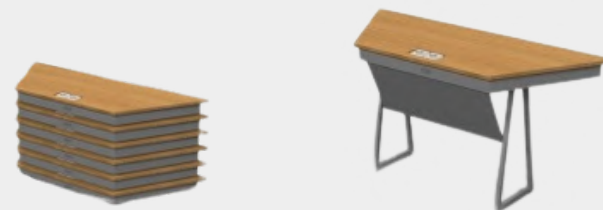
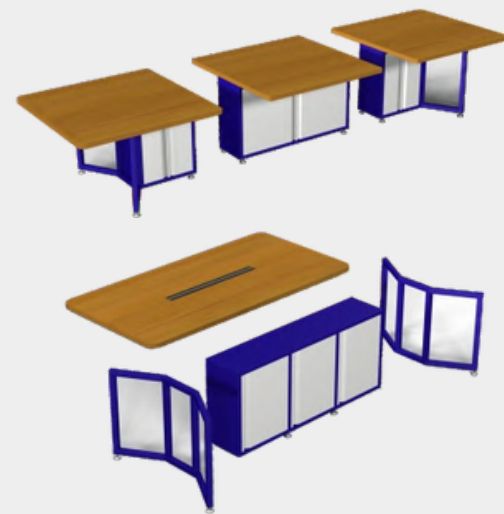

1 05 032 B



1 05 032 A

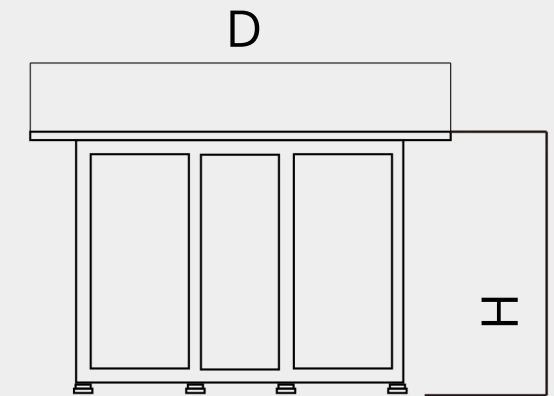
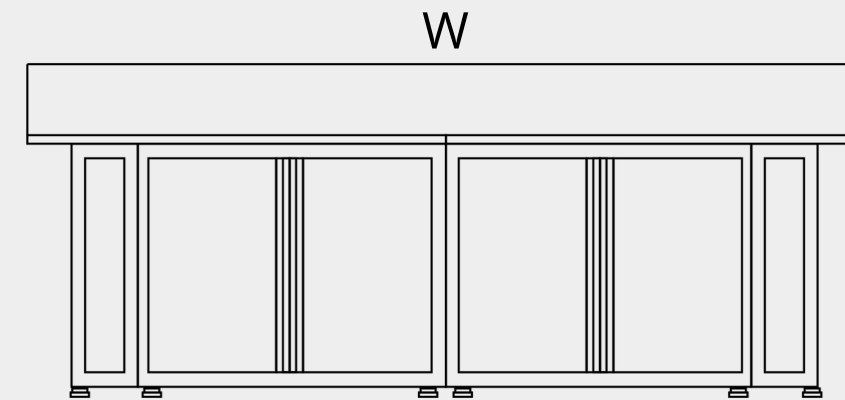

Spesification

Dimension (mm)	W	x	D	x	H
1 05 030	4000	x	1200	x	750
1 05 031	2400	x	1200	x	750
1 05 032 A	1500	x	600	x	760
1 05 032 B	1370	x	520	x	760

- Material**
- Steel plate cold-rolled coiled (SPCC - JIS G 3141)
Thickness 0.9 mm
 - Square Pipe / Round Pipe
 - Plywood covered by HPL / Mega Teak

- Features**
- Power Socket
 - Plastic Foot / Foot Adjuster

Finishing Electrostatic Powder Coating

CHAIR SERIES



0 06 001



0 06 002



0 06 003

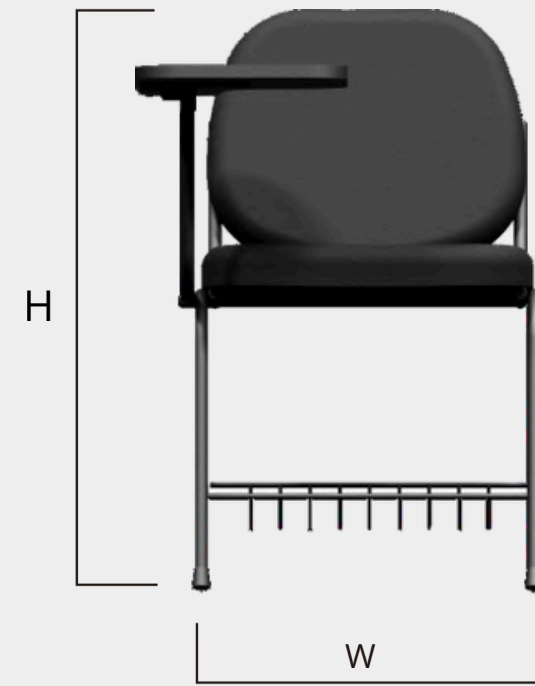

Spesification

Dimension (mm)

W x D x H (in mm)

0 06 001
0 06 002
0 06 003

488 x 530 x 885
488 x 530 x 885
488 x 530 x 885

Material

- MS pipe
- Plywood lined with foam and covered by imitation leather or vinyl

Finishing

Electrostatic Powder Coating

CHAIR SERIES



0 06 015



0 05 016



0 06 017



0 06 018

Spesification

Dimension (mm)

0 06 015 - 0 06 016
0 06 017 - 0 06 018

W x D x H x H1 x H2

500 x 500 x 830 x 460

500 x 500 x 830 x 460 x 765

Material

- Ms pipe or Stainless steel pipe
- Plywood with HPL / Mega Teak

Finishing

Electrostatic Powder Coating

CHAIR SERIES



0 06 004



0 06 005



0 06 006



0 06 007

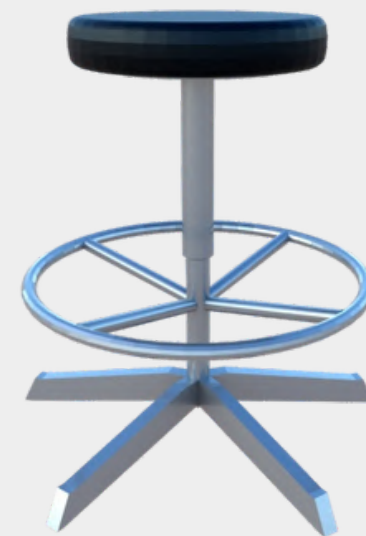

0 06 008

Spesification

Dimension (mm)

W x D x H x ϕ

0 06 004

585 x 566 x 750-800

0 06 005

585 x 566 x 750-800

0 06 006

585 x 566 x 750-800

0 06 007

550 x 550 x 500-750 x 320

0 06 008

550 x 550 x 500-750 x 320

Material

- Square pipe and round pipe
- Stainless steel
- Plywood lined with foam and covered by imitation leather or vynil

Features

- Rubber wheel with 2 inch diameter

Finishing

Electrostatic Powder Coating

CHAIR SERIES



0 06 009



0 06 010

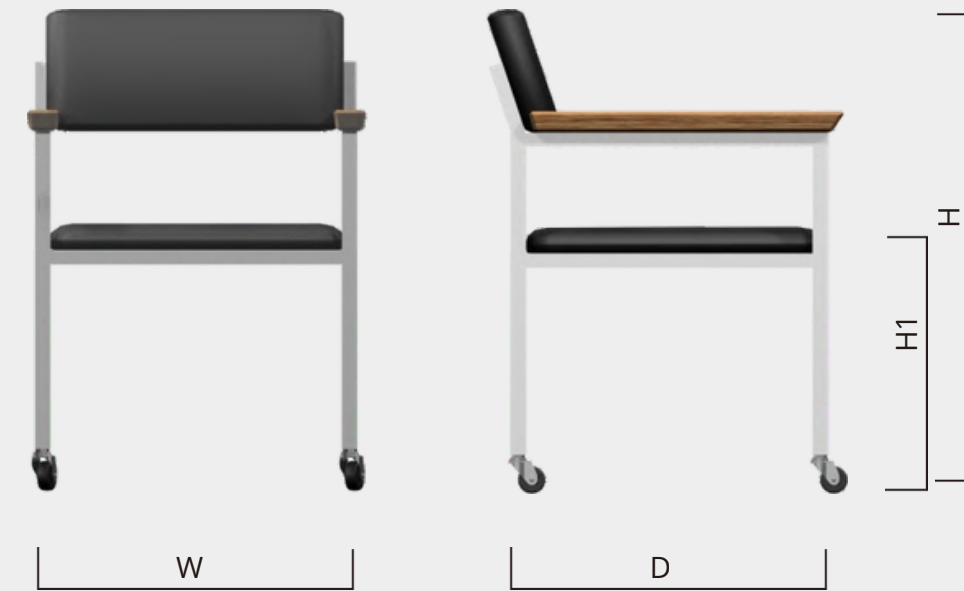

Spesification

Dimension (mm)

0 06 009
0 06 010

W x D x H x H1

530 x 470 x 835 x 475
530 x 470 x 840 x 480

Material

- Square pipe
- Teak wood with Nc finishing
- Plywood lined with foam and covered by imitation leather or vynil

Features

- Rubber wheel with 2 inch diameter

Finishing

Electrostatic Powder Coating



CHAIR SERIES



0 06 019



0 06 020

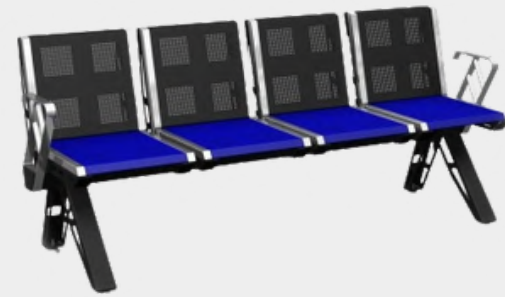

0 06 021



0 06 022

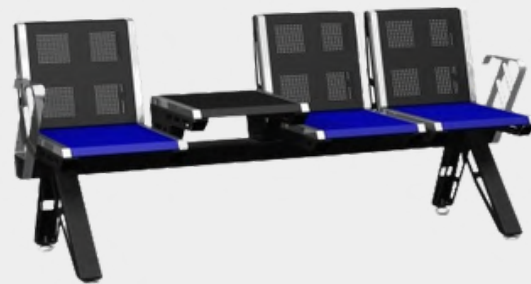

0 06 023



0 06 024

Spesification

Dimension (mm)	L x D x H x H1 x W
0 06 019	1020 x 600 x 790 x 410 x 450
0 06 020	1510 x 600 x 790 x 410 x 450
0 06 021	2000 x 600 x 790 x 410 x 450
0 06 022	1510 x 600 x 790 x 410 x 450
0 06 023	2000 x 600 x 790 x 410 x 450
0 06 024	2440 x 600 x 790 x 410 x 450

Material

- Steel plate cold-rolled coiled (SPCC - JIS G 3141)
Thickness 0.9 - 2.8 mm
- Stainless steel pipe 20x20

Features

- Equipped with foot adjuster
- Equipped with Hand rest
- Available with Perforate logo / symbol on back rest (by request)

Finishing Electrostatic Powder Coating



CABINET SERIES



Specification

Dimension (mm)	W	D	H	W1	D1	H1
1 01 001	485	675	680	424	628	294
1 01 002	485	675	976	424	628	294
1 01 003	485	675	1272	424	628	294
1 01 004	485	675	1272	424	628	294
1 01 005	485	675	1272	424	628	294

Material - Steel plate cold-rolled coiled (SPCC - JIS G 3141)
Thickness 0.9 - 2.8 mm

Features

- Name Plate
- Central lock system (laser cut key)
- Folio size drawer compartment
- Stainless steel handle
- Special runner construction

Finishing Electrostatic Powder Coating

Optional Accesories - Trolley

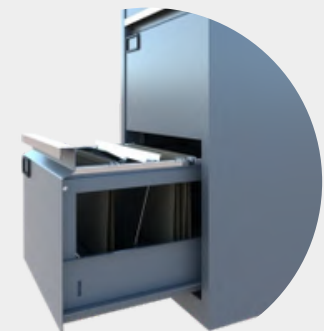

Folio size drawer



Special runner construction



Laser cut key



Trolley
(optional accesories)

CABINET SERIES

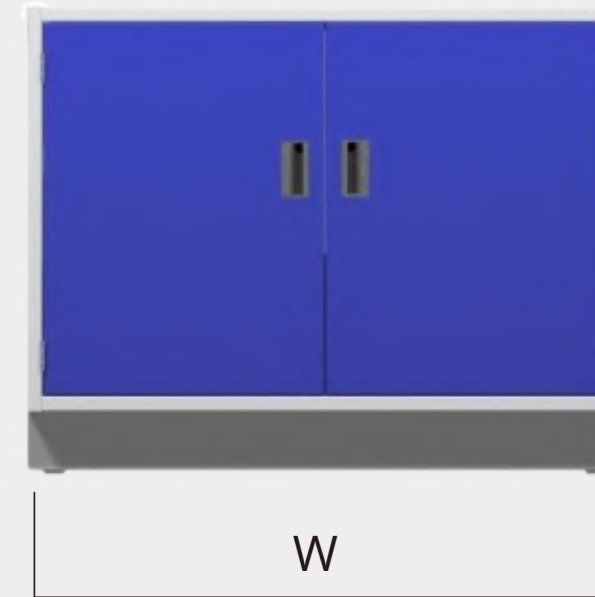
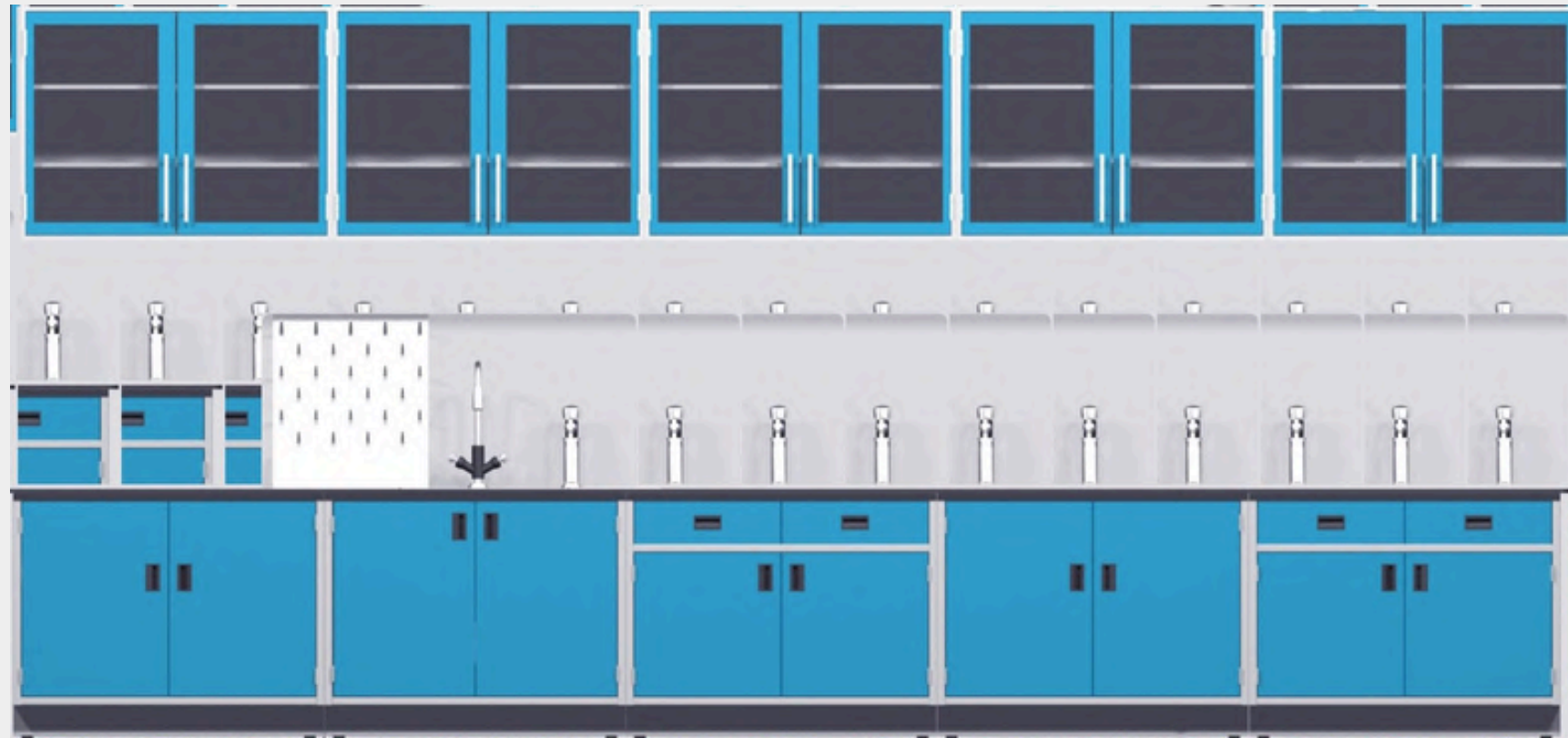

Spesification

Dimension (mm)	W	x	D	x	H
0 01 015	500		500		800
0 01 016	1000		500		800
0 01 017	1000		500		800
0 01 018	1000		300		750
1 01 013	1200		400		760
1 01 014	1200		400		1090

Material

- Steel plate cold-rolled coiled (SPCC - JIS G 3141)
Thickness 0.9 mm

Features

- Adjustable Shelves
- Rubber foot Adjuster

Finishing

Electrostatic Powder Coating



0 01 015



0 01 016



1 01 013



0 01 017



0 01 018



1 01 014

CABINET SERIES



0 02 005

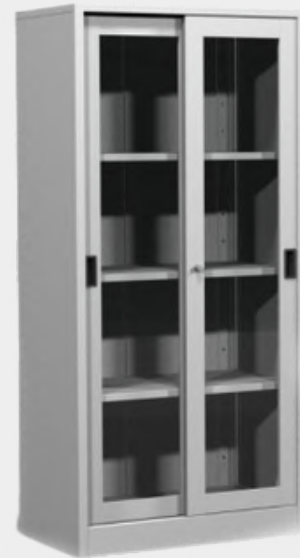

0 02 007



0 02 008



0 02 009



Laser cut key



Plastic handle

Specification

Dimension (mm)	W	D	H
0 02 005	880	482	1825
0 02 007	880	482	1825
0 02 008	850	390	1800
0 02 009	880	480	1825
0 02 017	980	300	760
0 02 019	1050	600	2250
1 02 001	1050	600	2250
1 02 002	1050	515	2250

Material

- Steel plate cold-rolled coiled (SPCC - JIS G 3141) Thickness 0.9 - 2.8 mm
- Steel / Glass

Features

- Adjustable shelving,
- Cam lock / Push Lock

Finishing

Electrostatic Powder Coating

Optional Accessories

- Trolley
- Extra Shelving



0 02 017



0 02 019



1 02 001



1 02 002



Trolley
(Optional Accesories)

CUPBOARD SERIES



0 02 020



0 02 021

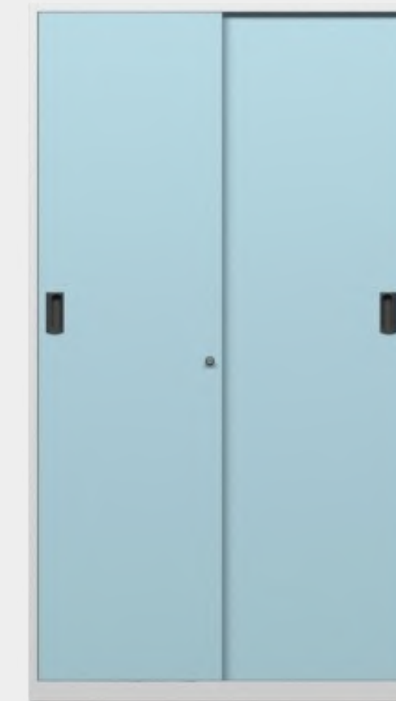

W



D

H



0 02 022



Specification

Dimension (mm)	W	D	H
0 02 020	1000	500	1800
0 02 021	1000	500	1800
0 02 022	1000	500	1800

Material - Steel plate cold-rolled coiled (SPCC - JIS G 3141)
Thickness 0.7 - 0.9 mm

Features - Plastic handle
- Cam lock / Push Lock
- Hanger pole

Finishing Electrostatic Powder Coating

Optional Accessories - Trolley
- Extra Shelving

LOCKER SERIES



0 03 006



0 03 007



0 03 008



0 03 009

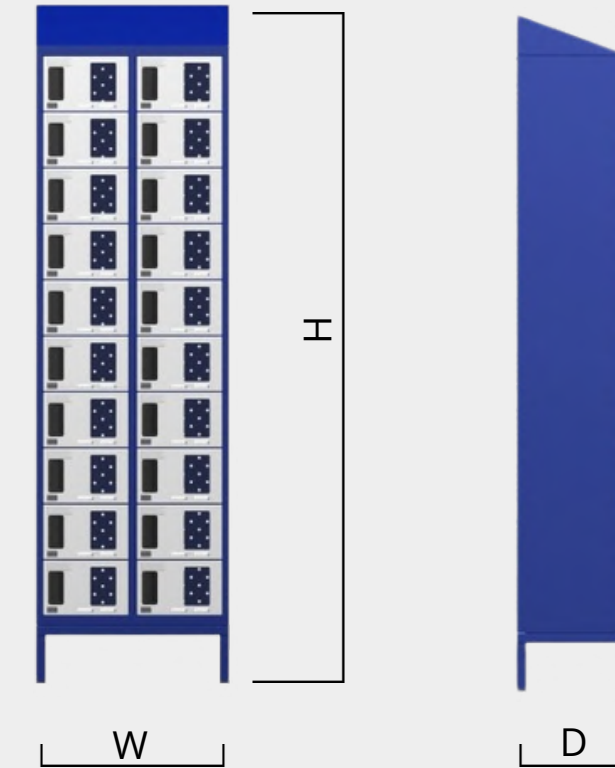

0 03 010

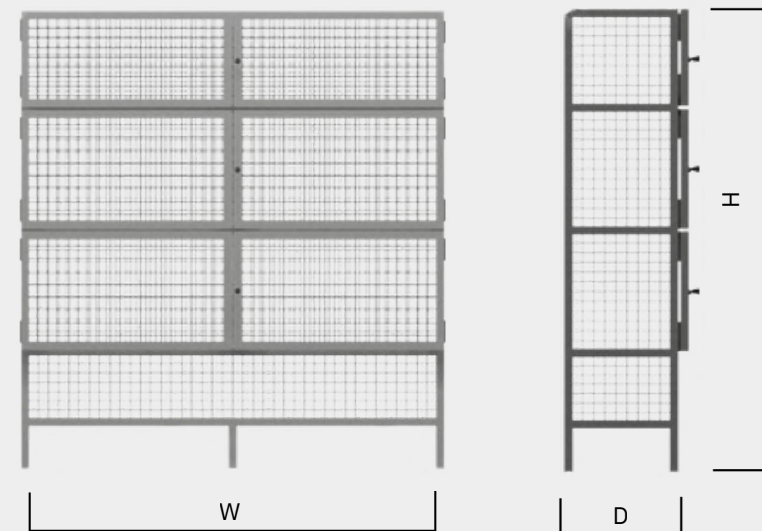

Spesification

Dimension (mm)

W x D x H

0 03 006 - 0 03 007

310 x 350 x 2110

0 03 008 - 0 03 009

600 x 350 x 2110

0 03 010

1500 x 440 x 1620

Material

- Steel plate cold-rolled coiled (SPCC - JIS G 3141)
Thickness 0.9 mm
- Square pipe
- Wiremesh

Features

- Cam lock / Combination lock

Finishing

Electrostatic Powder Coating

LOCKER SERIES

0 03 001 6 0 03 001 5 0 03 001 4 0 03 001 3 0 03 001 2 0 03 001 1



Optional part

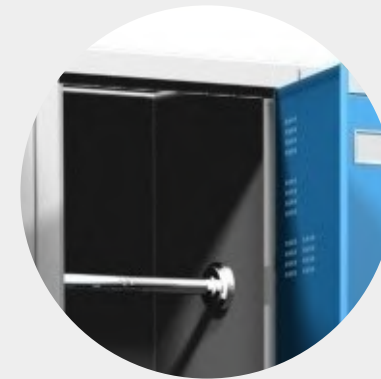

Hanger bar



Combination key

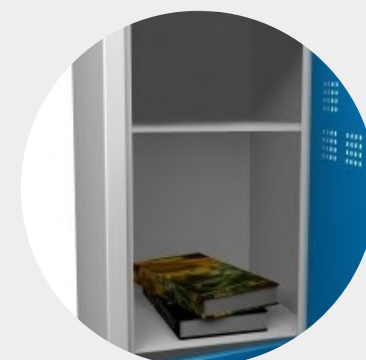

Additional Shelf

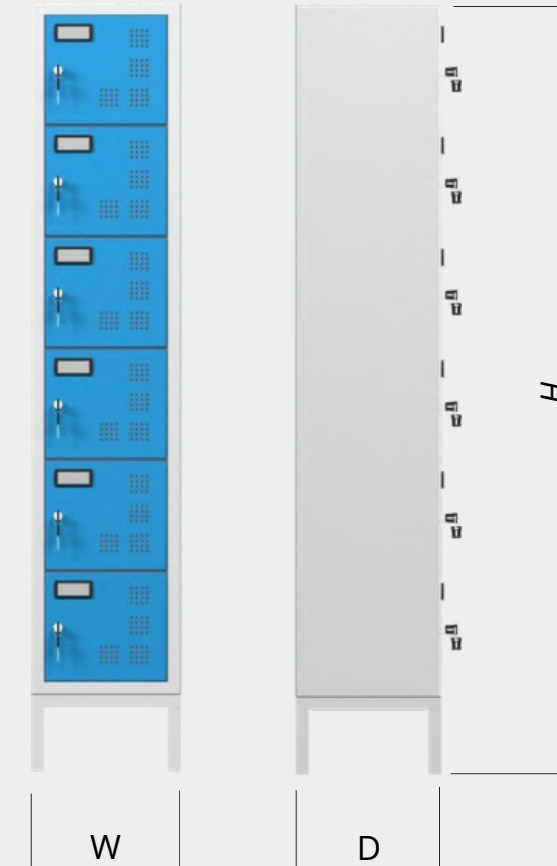

Locker Row

Locker Custom

Spesification

Dimension (mm)

W x D x H

350 x 340 x 1800

Material

- Steel plate cold-rolled coiled
(SPCC - JIS G 3141)
Thickness 0.9 mm

Features

- Name Plate
- Equipped with Cam lock
(available with combination lock)
- Door equipped with perforated hole for air ventilation

Finishing

Electrostatic Powder Coating

MOBILE FILE



1 04 012

1 04 001

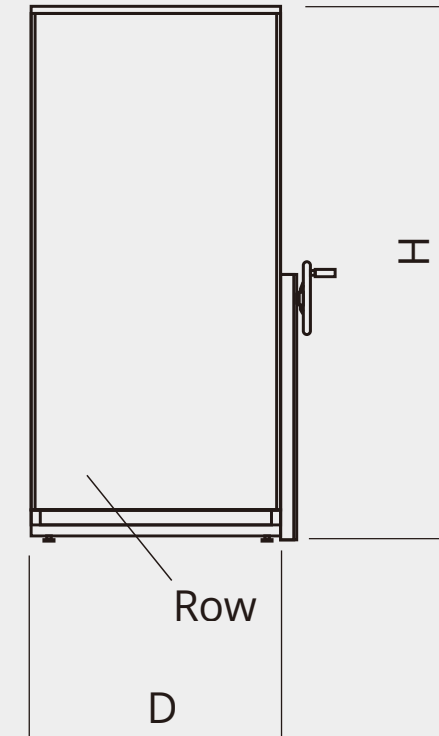
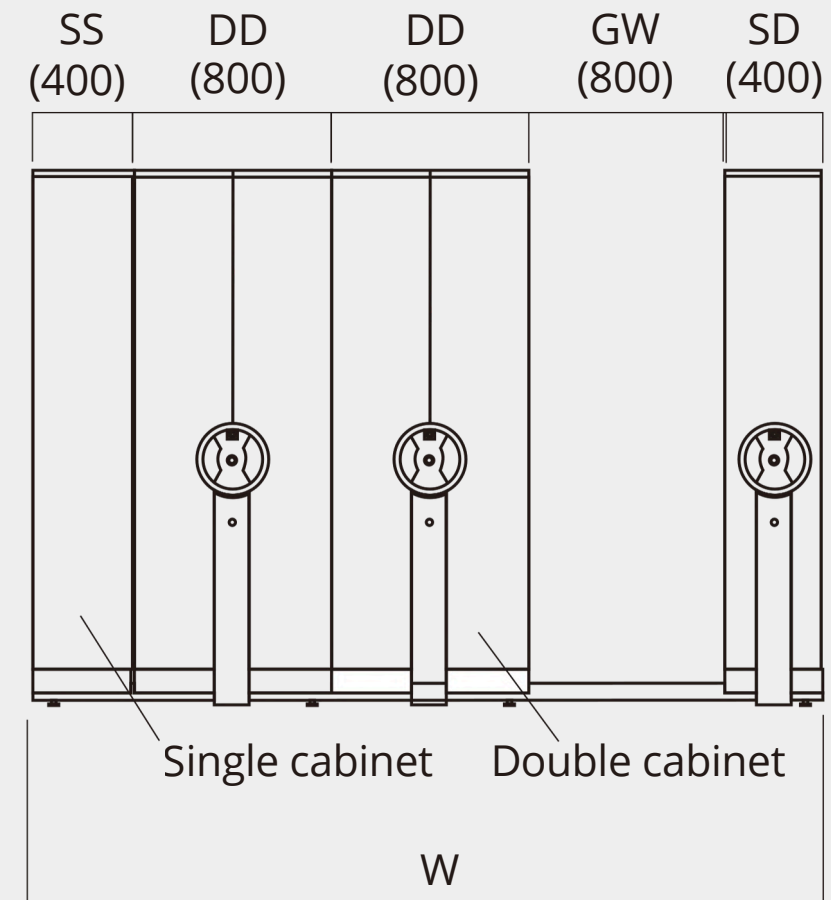
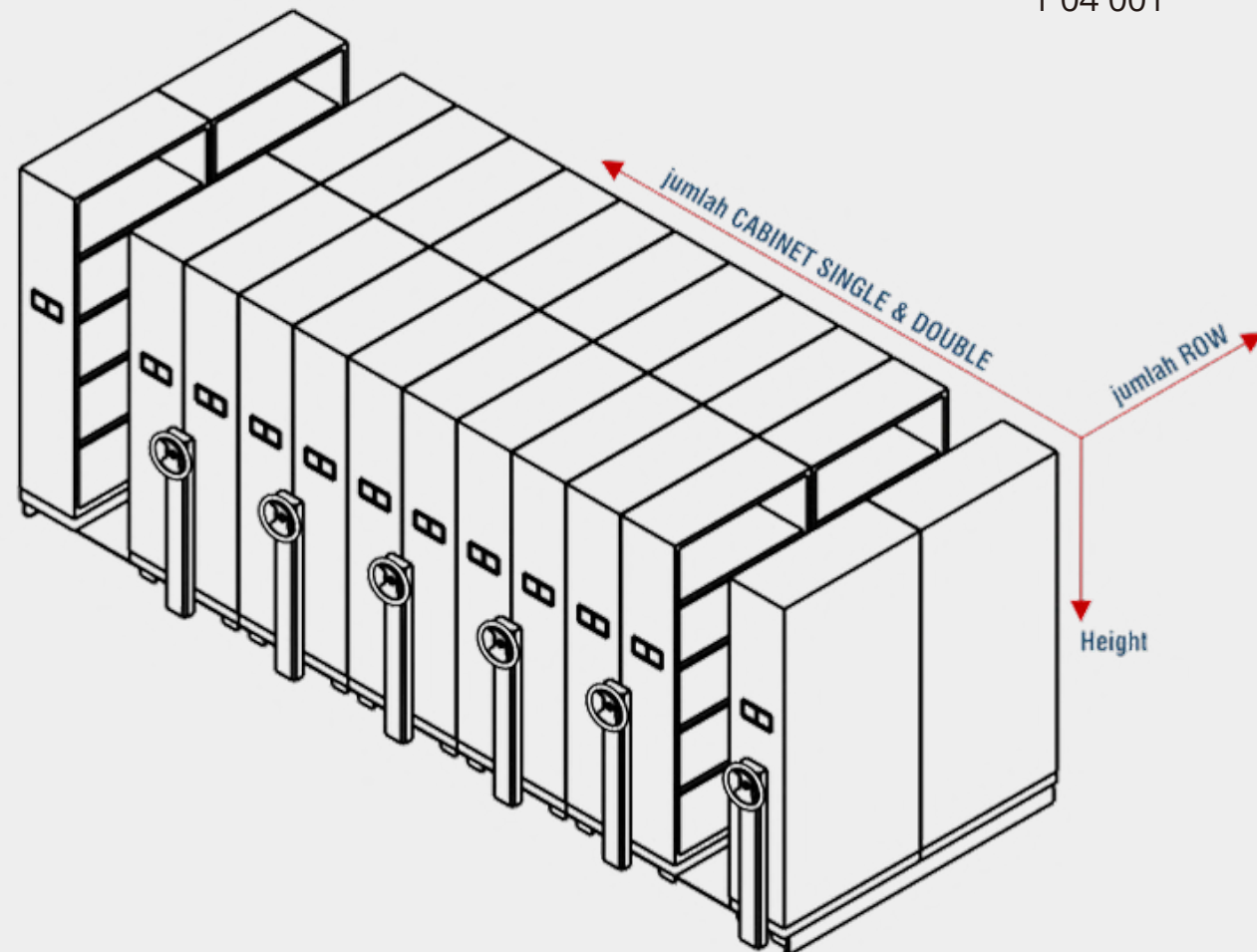

Spesification

Dimension (mm)	W x D x H
1 04 101 / 1 04 001 (1 x DD)	2400 x 1000 x 2210
1 04 102 / 1 04 002 (2 x DD)	3200 x 1000 x 2210
1 04 103 / 1 04 003 (3 x DD)	4000 x 1000 x 2210
1 04 104 / 1 04 004 (4 x DD)	4800 x 1000 x 2210
1 04 105 / 1 04 005 (5 x DD)	5600 x 1000 x 2210
1 04 106 / 1 04 006 (6 x DD)	6400 x 1000 x 2210
1 04 107 / 1 04 007 (7 x DD)	7200 x 1000 x 2210
1 04 108 / 1 04 008 (8 x DD)	8000 x 1000 x 2210
1 04 109 / 1 04 009 (9 x DD)	8800 x 1000 x 2210
1 04 110 / 1 04 010 (10 x DD)	9600 x 1000 x 2210

Material

- Steel plate cold-rolled coiled (SPCC - JIS G 3141)
- Thickness 0.9 - 2.8 mm
- Multiplex covered Vinyl

Features

- Plastic Name Plate
- Camlock Key
- Capacity 60 ordner / cabinet
- 4 Shelves/cabinet (5 compartment)

Finishing Electrostatic Powder Coating

BOARD SERIES



1 08 001

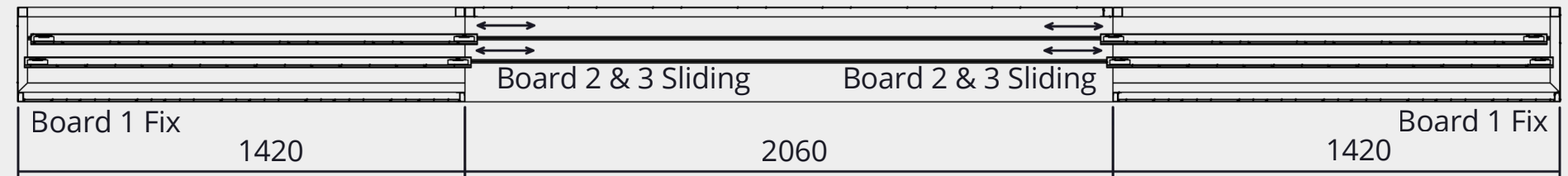

Spesification

Dimension (mm)

W x D x H

1 08 001

1672 x 400 x 2000

1 08 002

4900 x 300 x 1500

Material

- Steel plate cold-rolled coiled (SPCC - JIS G 3141)
- Square pipe 40x40
- Plywood with HPL
- Glass 5 mm

Features

- Board can be rotate 360 degree and equipped stopper
- Front board : Fix, with 2 Sliding board each
- Castor Wheel

Finishing

Electrostatic Powder Coating

WORKSHOP EQUIPMENT



PRODUCTS

WORKBENCH

TOOL CART

TOOL CABINET

RACKING SYSTEM



2 05 034



2 05 035



2 05 036



2 05 037



2 05 038



2 05 039



2 05 040



WB with 2 Vise



WB with Mobile Drawer

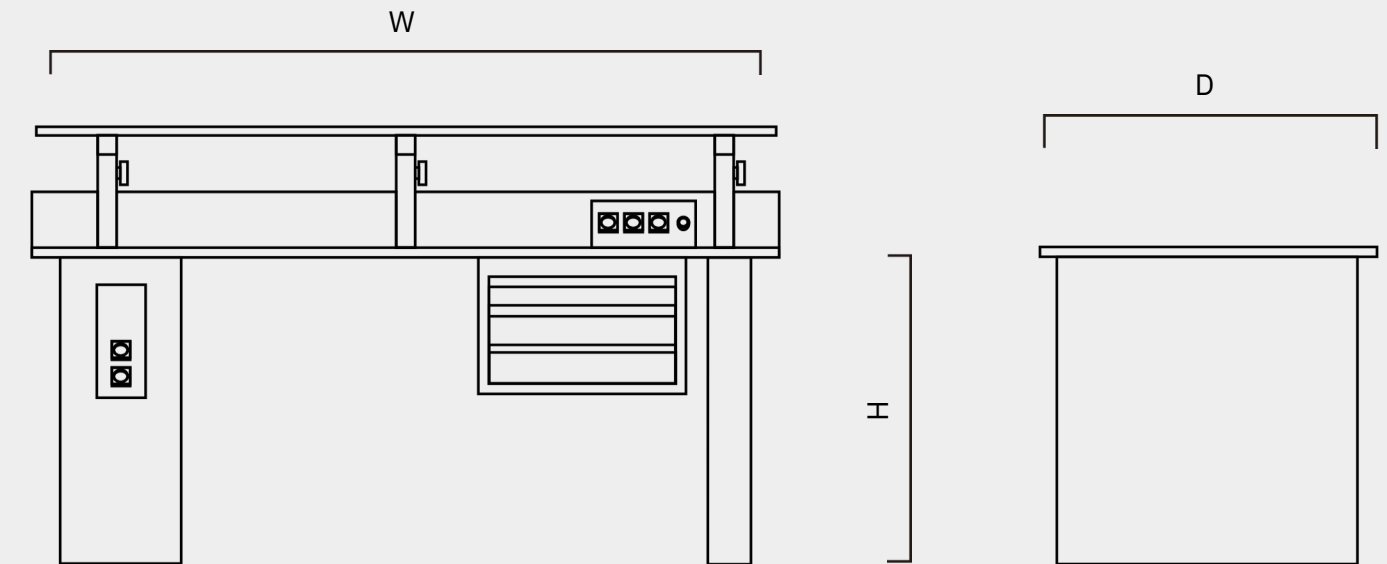

Spesification

Dimension (mm)	W	D	H
2 05 034	2000	800	850
2 05 035	2500	800	850
2 05 036	2000	800	850
2 05 037	2000	800	825
2 05 038	2000	800	825
2 05 039	2000	800	825
2 05 040	2000	800	825
WB with 2 Vise	2000	800	850
WB with Mobile Drawer	2270	700	940

Material

- Steel plate cold-rolled coiled (SPCC - JIS G 3141)
Thickness 0.9 - 2.8 mm
- Solid wood / Plywood

Features

- Vice
- Power Socket

Finishing

Electrostatic Powder Coating

WORKBENCH SERIES



2 05 042



2 05 043

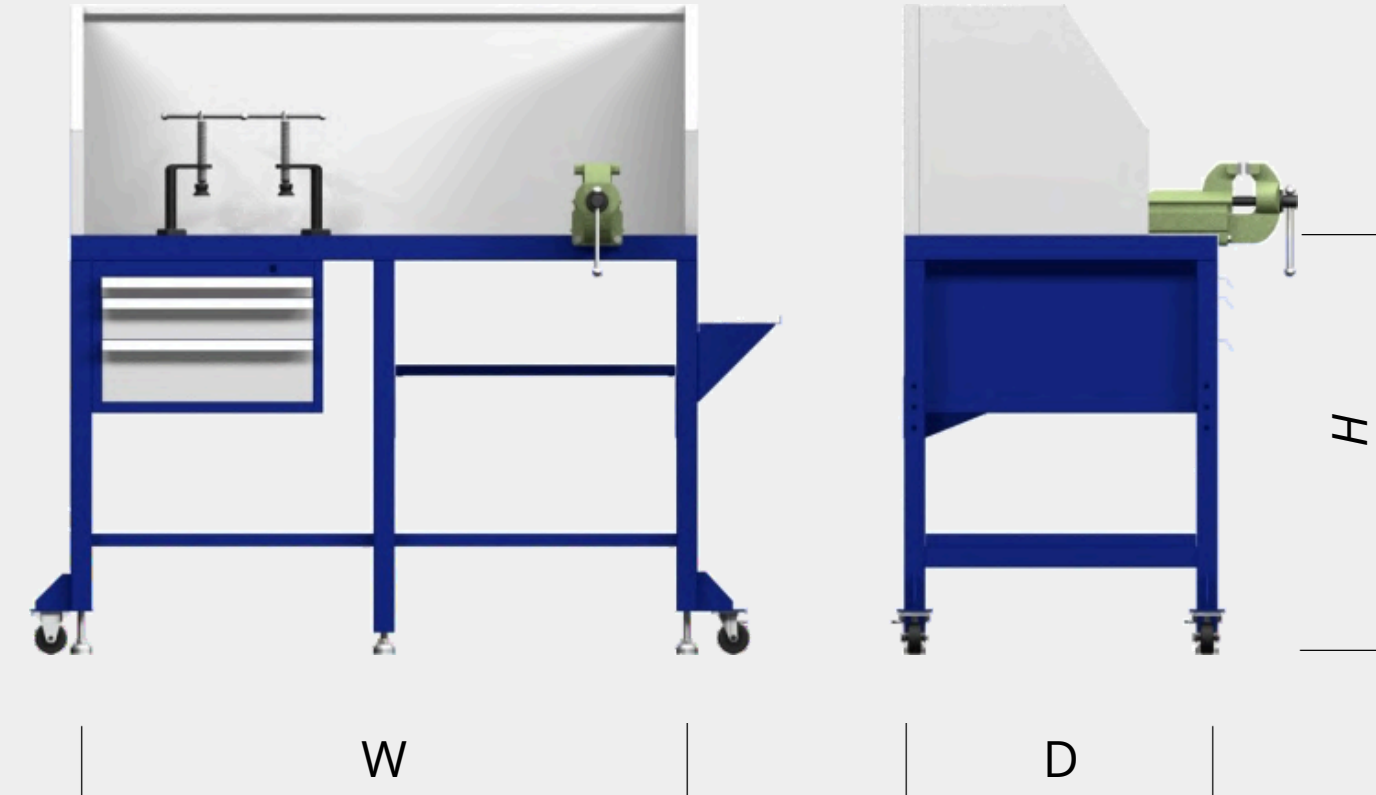

Spesification

Dimension (mm)	W x D x H
2 05 042	2480 x 1250 x 790
2 05 043	1500 x 750 x 1000
Material	<ul style="list-style-type: none"> - Square pipe - Steel plate cold-rolled coiled (SPCC - JIS G 3141) - FCD with 30mm thickness
Features	<ul style="list-style-type: none"> - Equipped with one Fix Vise - Equipped with two Clamping tool - Equipped with Foot Adjuster
Finishing	Electrostatic Powder Coating

TOOL CART SERIES



2 10 002

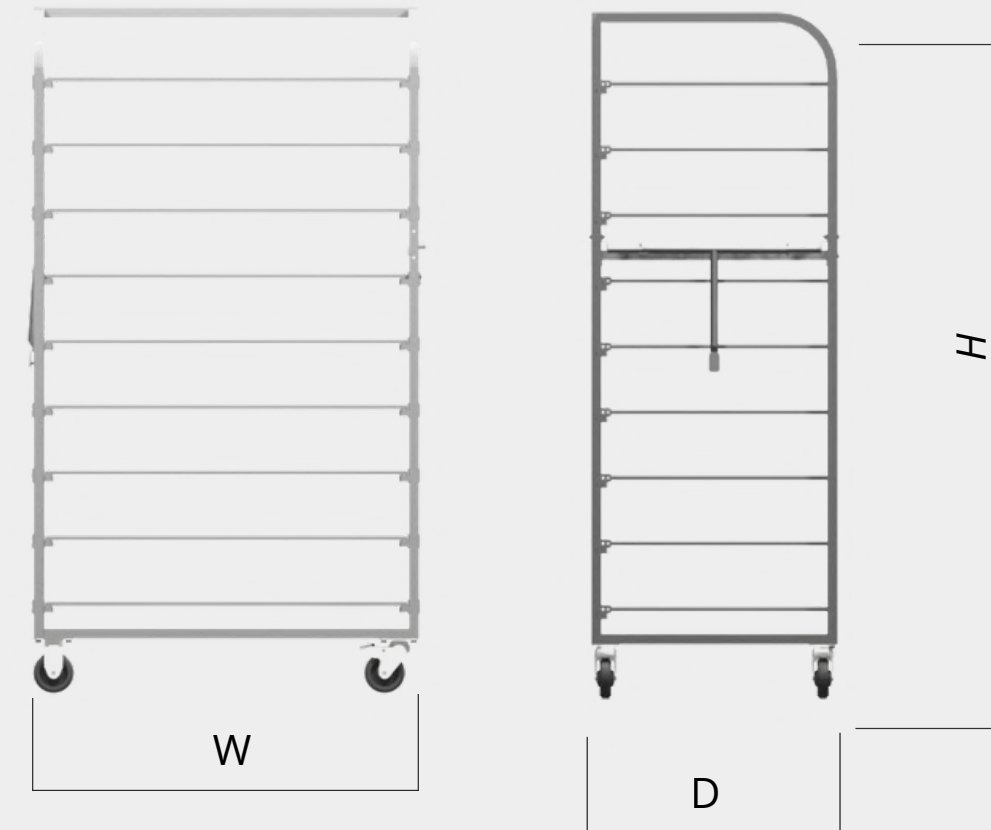
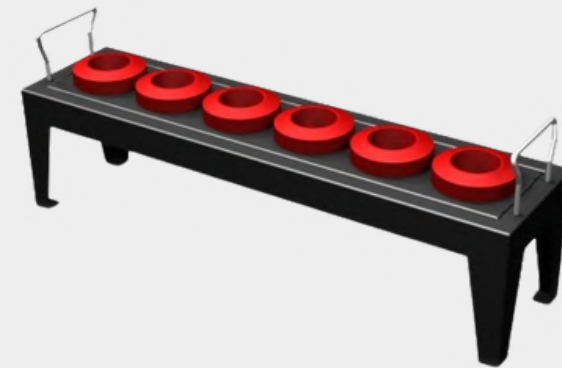

2 10 006

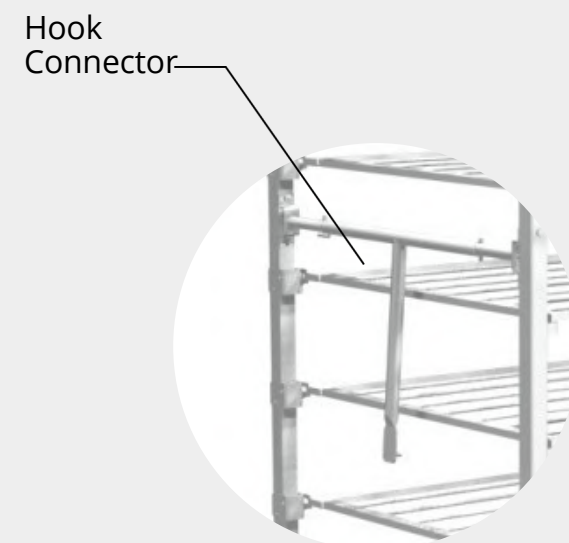

Spesification

Dimension (mm)	W x D x H
2 10 002	684 x 486 x 886
2 10 006	968 x 611 x 1802
Material	- Steel plate cold-rolled coiled (SPCC - JIS G 3141) Thickness 0.9 mm - Steel pipe 20x20
Features	- Two Static castor and Two swivel castor with brake
Finishing	Electrostatic Powder Coating

TOOL CABINET SERIES

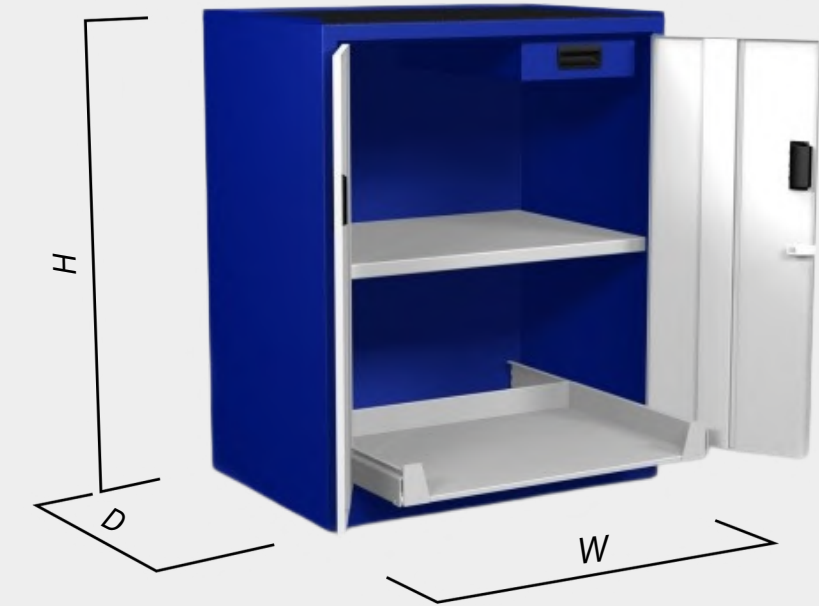

Specification



2 09 005 2 09 008 2 09 009 2 09 011 2 09 010 2 09 012 2 09 015

Dimension (mm)	W	x	D	x	H
2 09 005	1100		560		990
2 09 008	1100		560		990
2 09 009	717		546		1025
2 09 010	550		560		990
2 09 011	717		750		1025
2 09 012	800		560		990
2 09 015	800		560		990

Material

- Steel plate cold-rolled coiled (SPCC - JIS G 3141)
Thickness 0.9 mm

Features

- Door using swing sistem
- Adjustable Shelves position
- Equipped with one drawer inside with handle
- Top side of cabinet covered by imitation leather
- T-handle (Optional with Camlock type)
- Drawer can be pulled up to 100% of the length

Finishing

Electrostatic Powder Coating



Optional key



T-Handle*

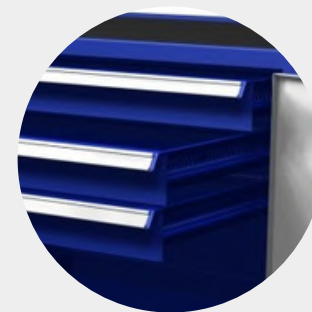

Drawer

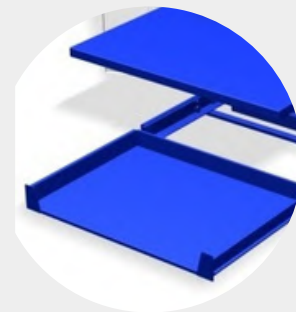

extension shelves

TOOL CABINET SERIES



2 02 022

2 02 023



2 02 024



2 02 025

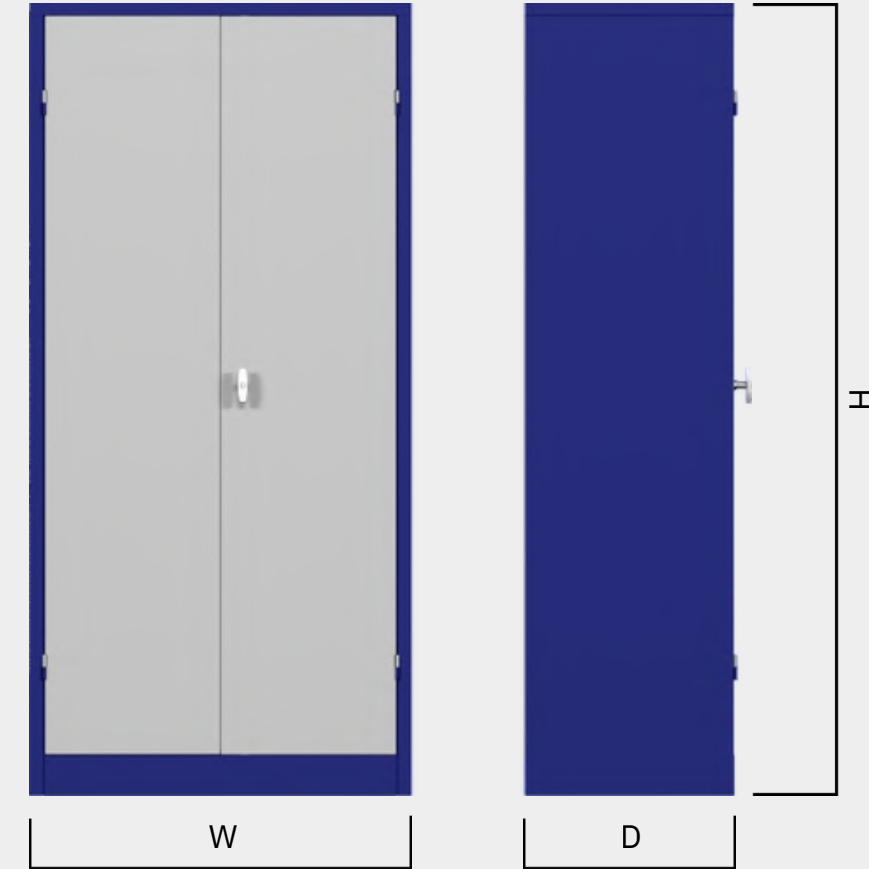

Spesification

Dimension (mm)	W x D x H
2 02 022	880 x 480 x 1825
2 02 023	1180 x 600 x 2000
2 02 024	1000 x 760 x 1800
2 02 025	1200 x 720 x 2300

Material	- Steel plate cold-rolled coiled (SPCC - JIS G 3141)
Features	- Equipped with Cam lock type - Adjustable Shelving - Available for BT30, BT40, HSK - Integrated cam lock type with handle
Finishing	Electrostatic Powder Coating

TOOL CABINET SERIES



2 09 001



2 09 002



2 09 016



W

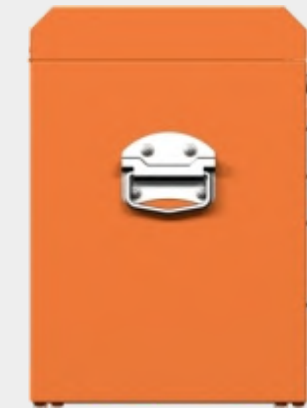

D

H

2 09 019

2 09 020

2 09 021

2 09 018

2 09 017



Spesification

Dimension (mm)	W x D x H
2 09 001	715 x 707 x 1060
2 09 002	1191 x 707 x 1060
2 09 016	765 x 450 x 740
2 09 017	450 x 200 x 230
2 09 018	655 x 312 x 442
2 09 019	680 x 465 x 910
2 09 020	1000 x 550 x 800
2 09 021	762 x 465 x 838

Material - Steel plate cold-rolled coiled (SPCC - JIS G 3141)
Thickness 0.9 - 2.8 mm

Features

- Central Locking System
- The drawer uses a construction which runs on ball bearings
- Cam lock type
- Plastic Handle
- Rubber wheel castors

Finishing Electrostatic Powder Coating

RACK SERIES

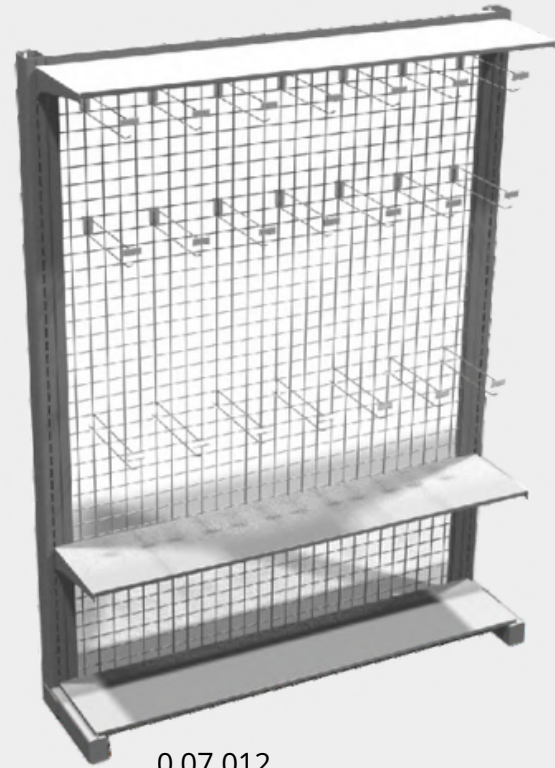

0 07 012



1 07 013

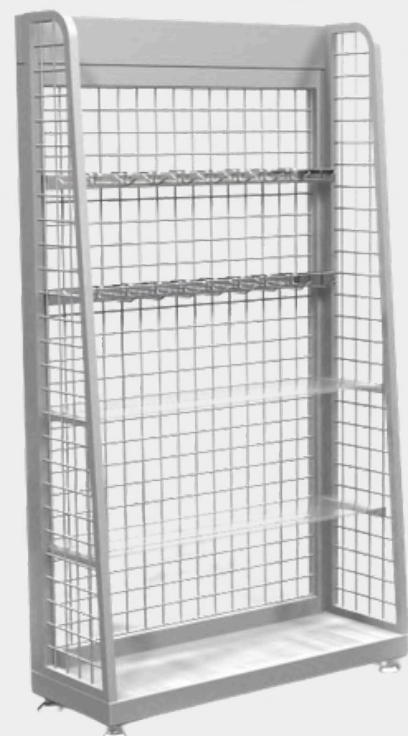

1 07 014

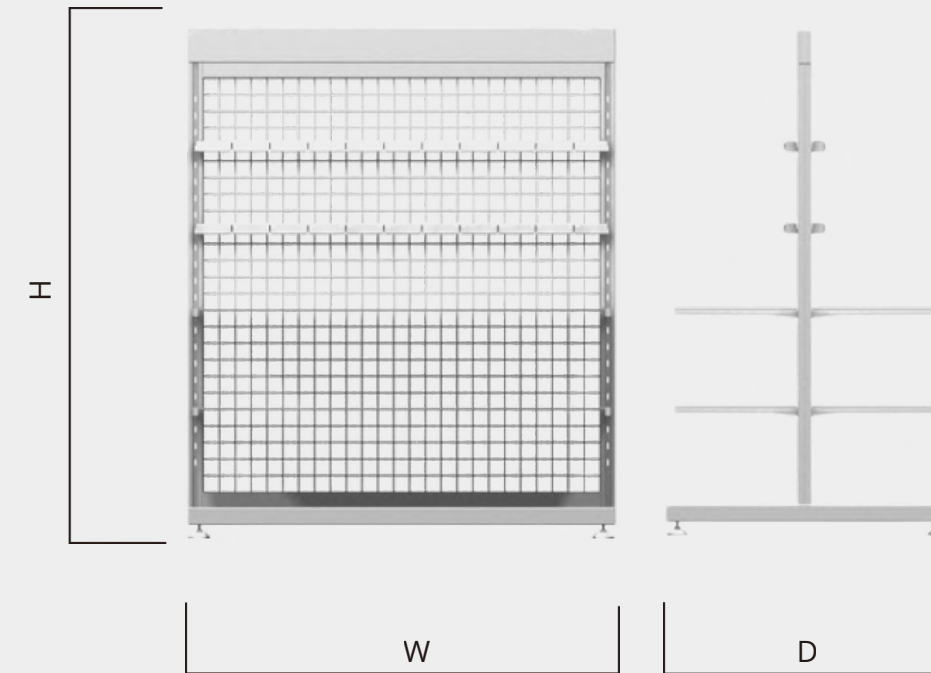

Spesification

Dimension (mm)

W x D x H

0 07 012

1500 x 390 x 2000

0 07 013

1200 x 800 x 1350

0 07 014

800 x 300 x 1350

Material

- Steel plate cold-rolled coiled (SPCC - JIS G 3141)
Thickness 0.9 mm
- Pipe
- Mesh
- Glass

Finishing

Electrostatic Powder Coating

RACK SERIES

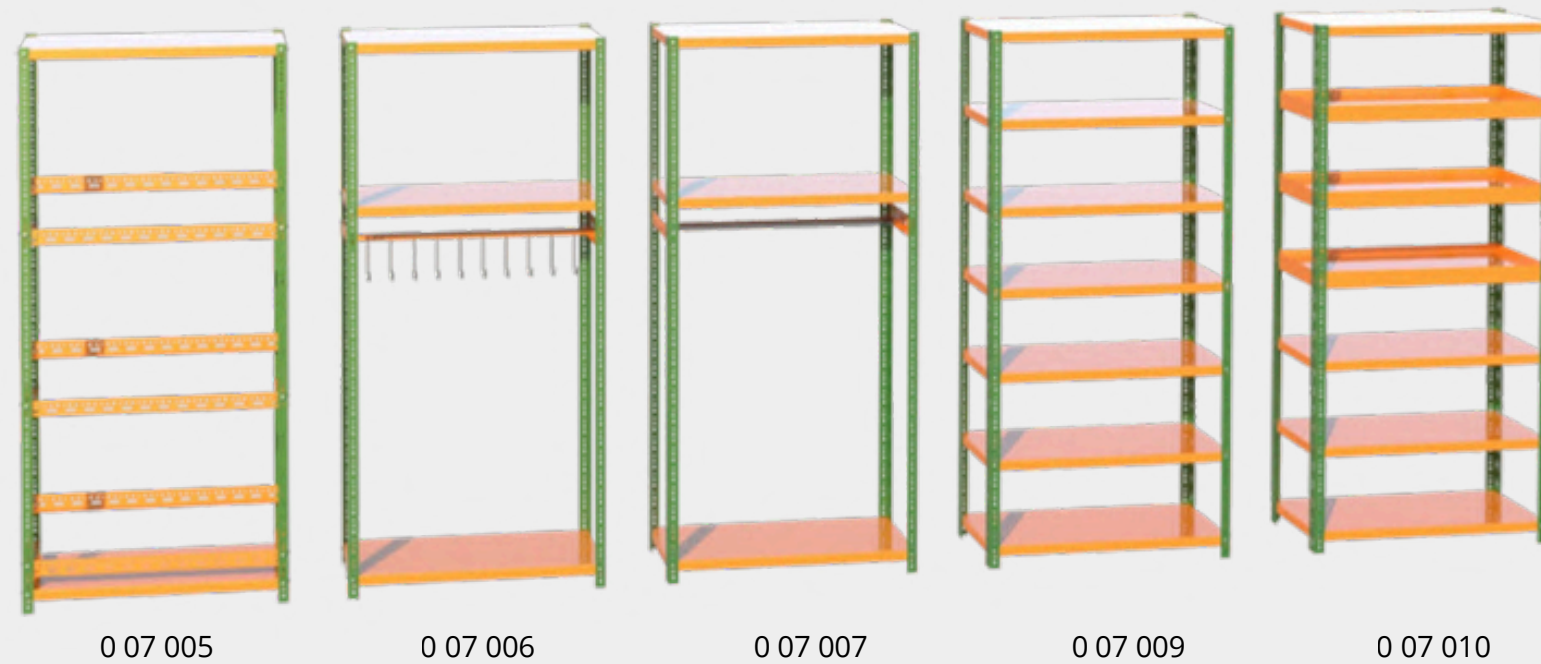
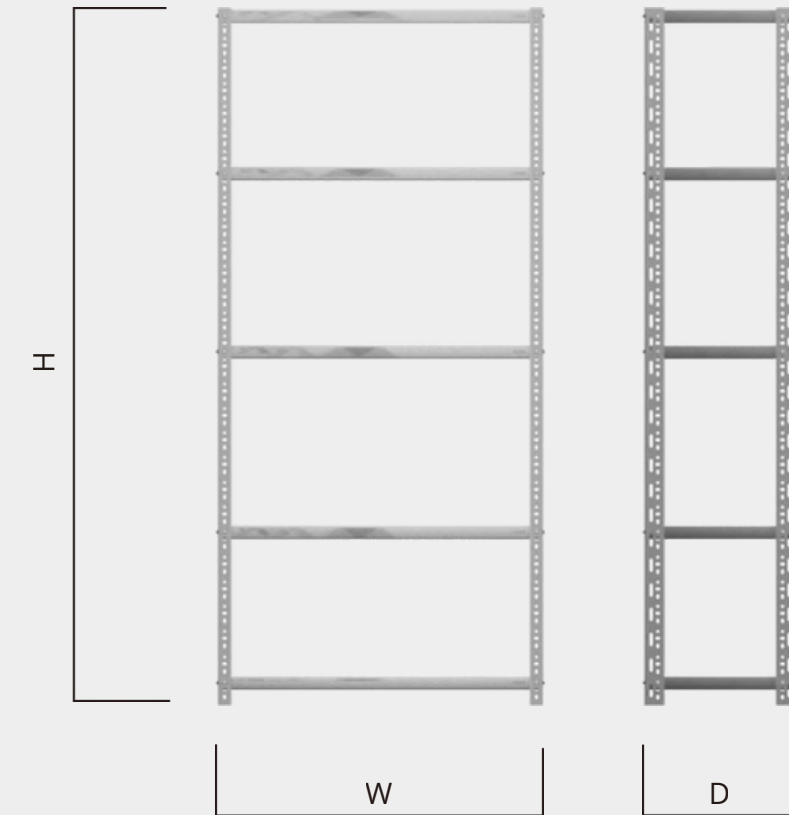
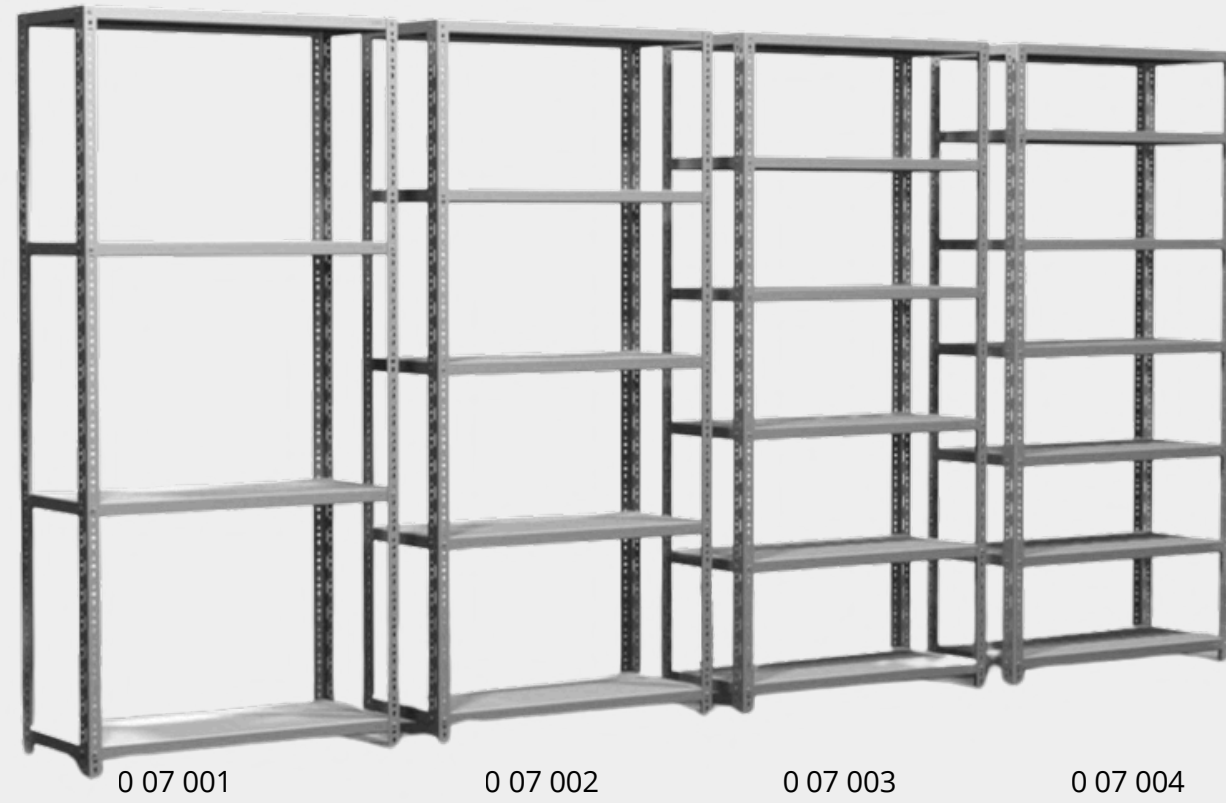

Spesification

Dimension (mm)

W x D x H

990 x 460 x 2130

Material

- Steel plate cold-rolled coiled (SPCC - JIS G 3141)
Thickness 0.9 - 1.8 mm

Finishing

Electrostatic Powder Coating

RACK SERIES



207011



207012

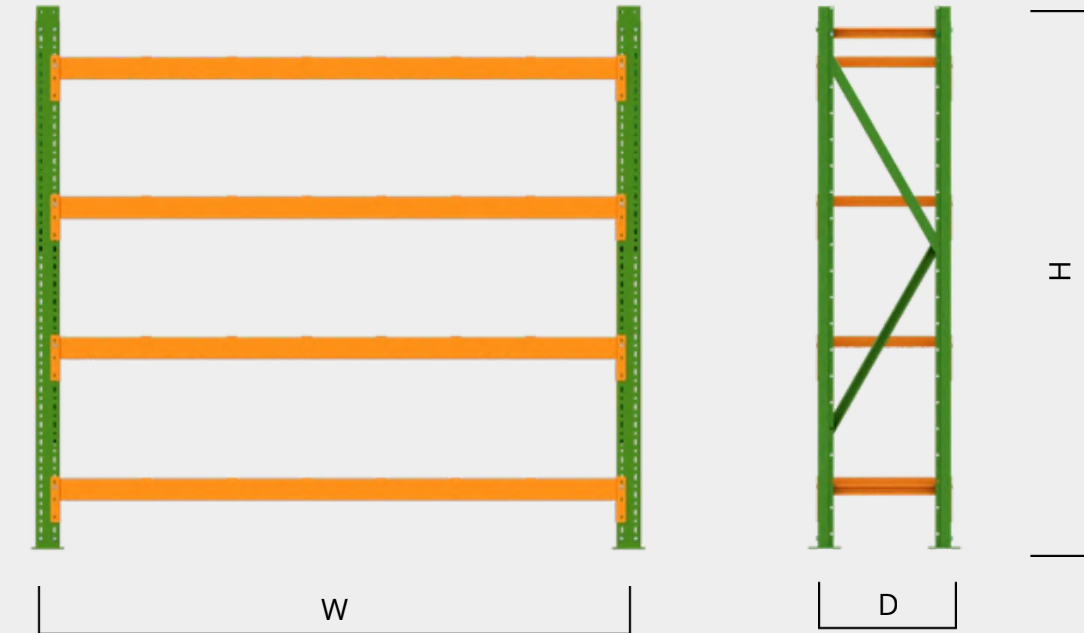

Spesification

Dimension (mm)	W x D x H
2 07 011	2000 x 600 x 2000
2 07 012	1750 x 1350 x 1550
Material	- Steel plate cold-rolled coiled (SPCC - JIS G 3141) Thickness 1.4 - 2.8 mm - MS Square Pipe - MS Profile
Features	- Max load 500 kg/rack
Finishing	Electrostatic Powder Coating

RACK SERIES

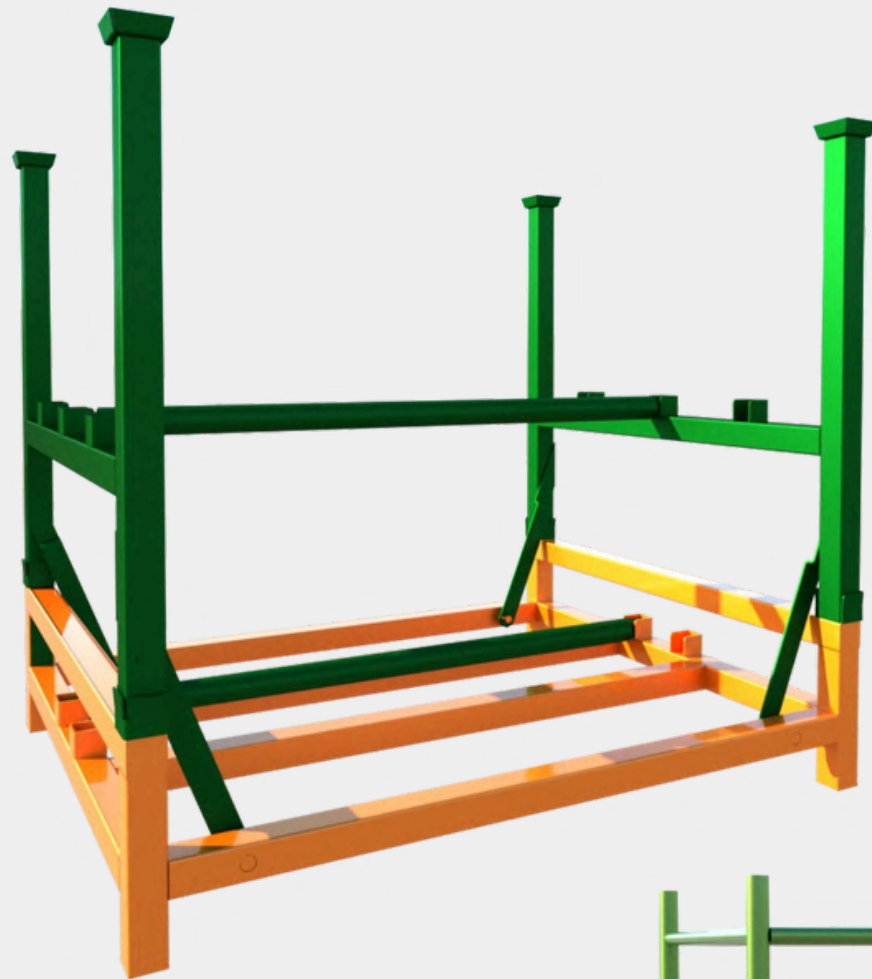

2 07 013



2 07 014

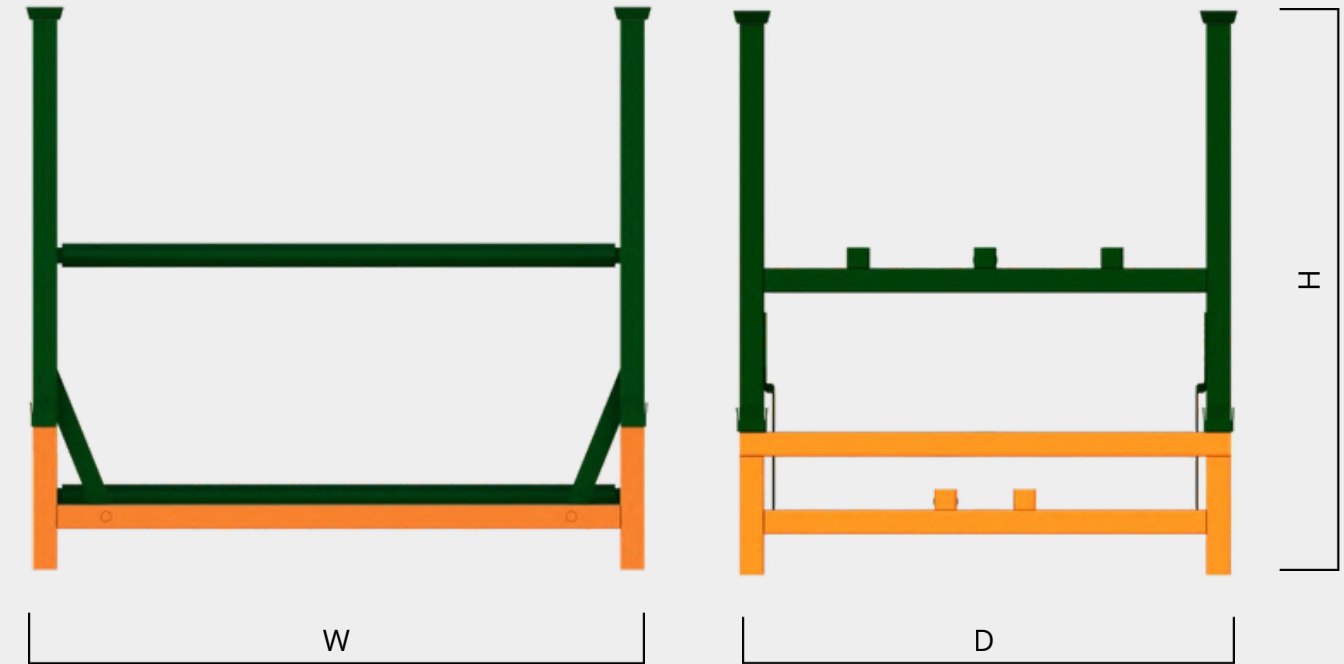

Spesification

Dimension (mm)	W x D x H
2 07 013	1500 x 1200 x 1350
2 07 014	1510 x 1105 x 1710
Material	- Steel plate cold-rolled coiled (SPCC - JIS G 3141) Thickness 1.4 - 2.8 mm - MS Pipe - MS Square Pipe - MS Profile
Finishing	Electrostatic Powder Coating

COLOR PALETTE



RED



CREAM



YELLOW



GREEN MACHINE



SKY BLUE



BLUE



GREEN BLUE



BLACK



GREY



LIGHT GREY

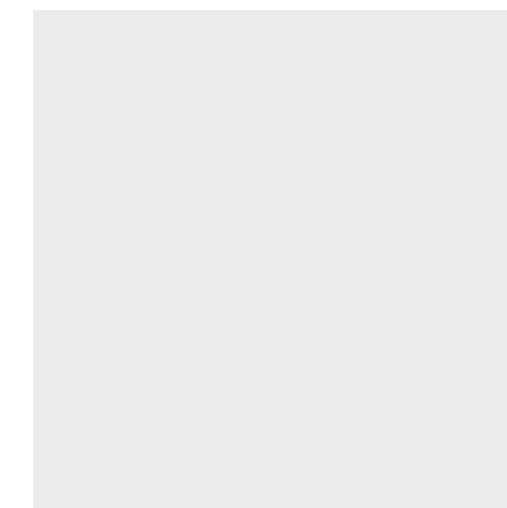

SIGNAL WHITE

MIM DIVISION



PRODUCTS

METAL INJECTION MOLDING





- I Factory and Office
- I Customer



PIM KOREA



PIM VINA

Overseas

USA

Mexico

France

Germany

China

Indonesia

Vietnam

Thailand

Poland

Slovakia

Czech

BORGWARNER



SAMSUNG

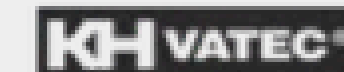

METAL INJECTION MOLDING



MATERIALS

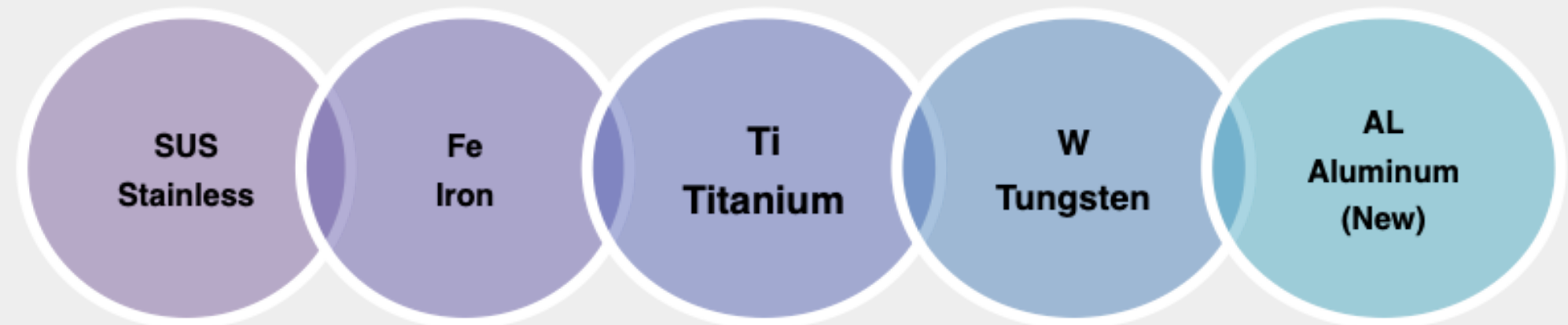

KNEADING

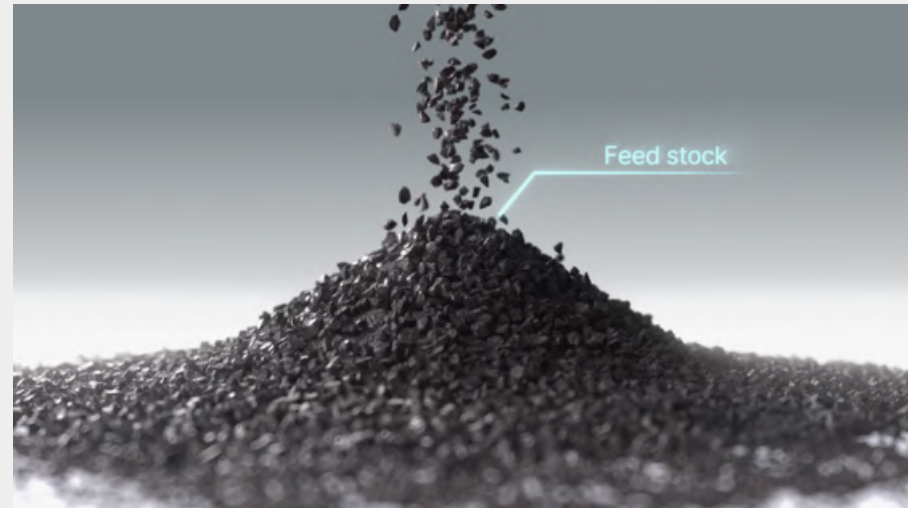

Metal powder + Binder



INJECTION

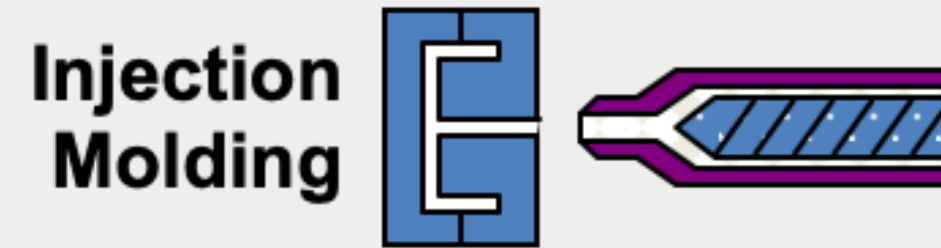

Shape made by injection



DEBINDING

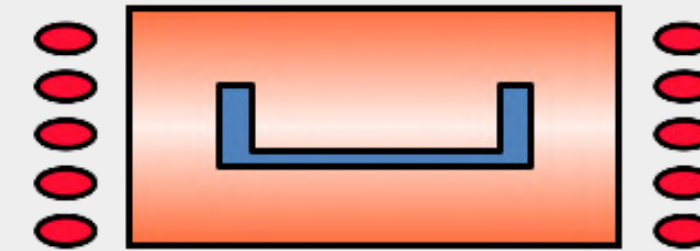

To remove binder

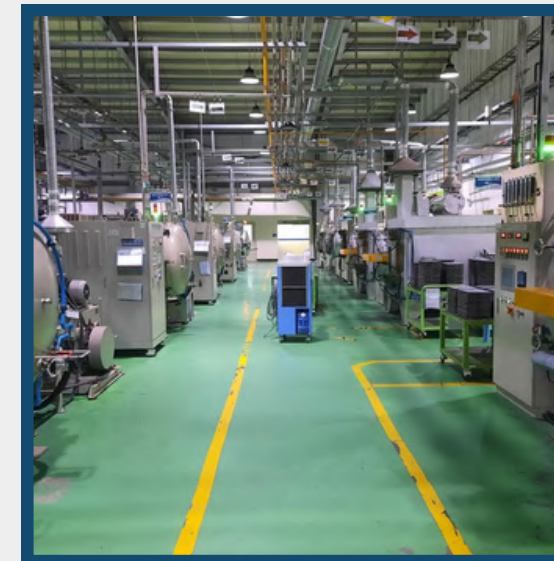

SINTERING

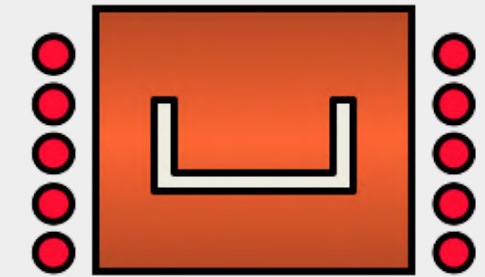

To compact it into a solid piece



MANUFACTURING PROCESS

KNEADING



Metal Powder + Binder

INJECTION



Shaping

DEBINDING



Binder removal

SINTERING



Mechanical property

MACHINING

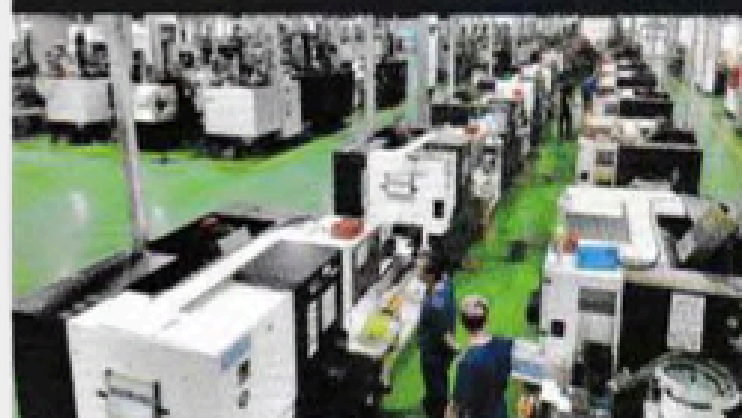

Turning, Milling, Grinding

ASSEMBLY



Press fitting, Spinning

MIM ADVANTAGES

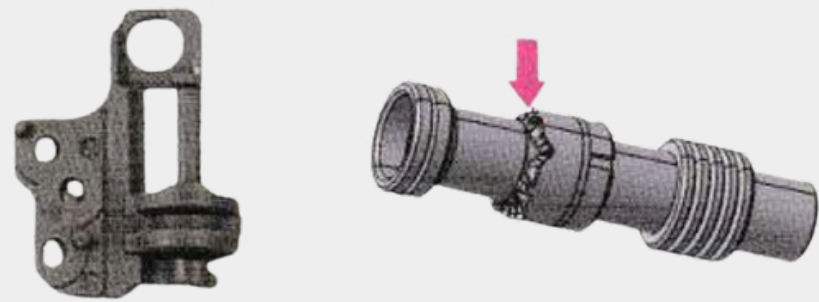

DESIGN FLEXIBILITY

50g Ti → 20g (Ti + Binder)



EFFICIENT MATERIAL USAGE

5 axis Machining → MIM + Machining



PM + Machining → MIM

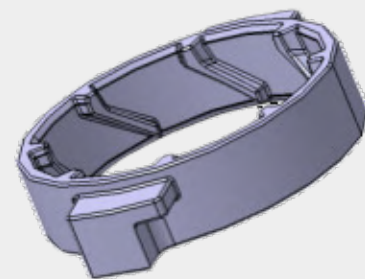

PROCESS SIMPLIFICATION

Assembly → MIM



Welding → MIM

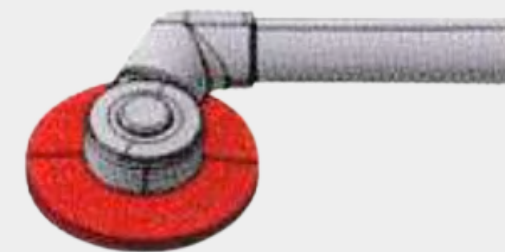

PARTS SIMPLIFICATION

APPLICATION

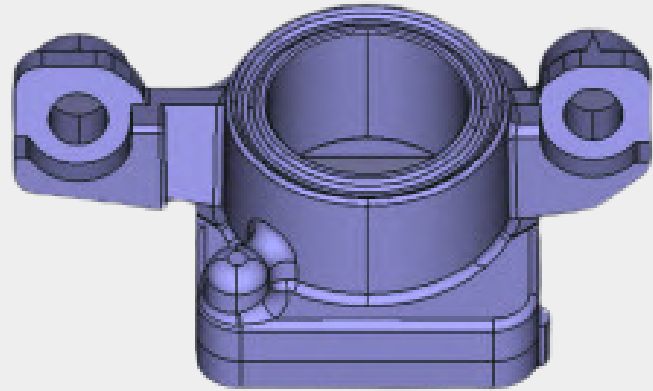

CAMERA MODULE

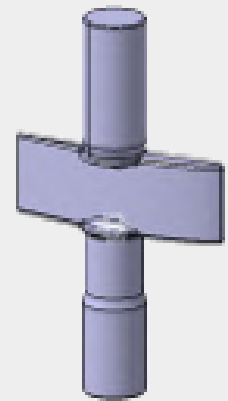

VANE

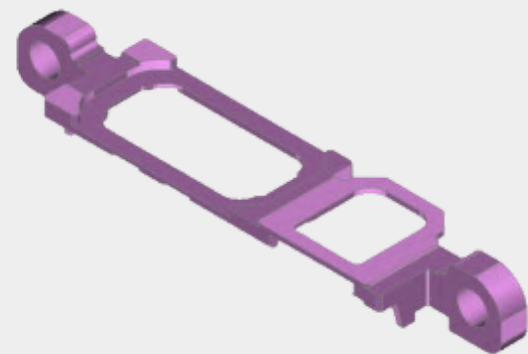

SMARTWATCH

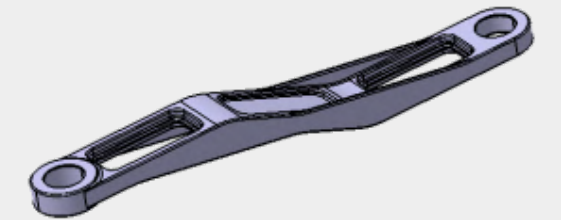

STEERING ROD

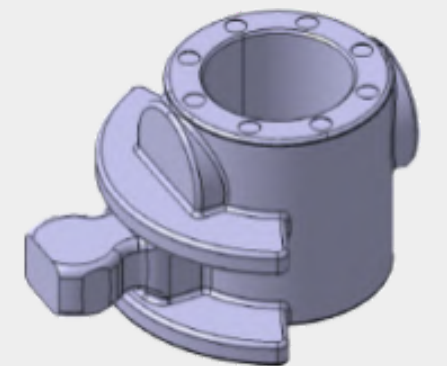

DUAL CLUTCH TRANSMISSION

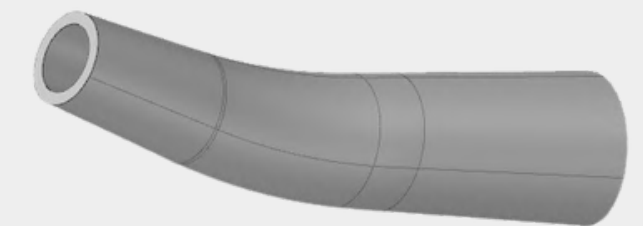

HAND PIECE (MEDICAL)

APPLICATION

Photo					
Part	WADRING	Control Shaft Assy	Clutch Body	PINION GEAR	SPLINE
Material	AISI4140	-	SUS630	Fe2%	Fe2%
Process	MIM	Assembly	MIM	MIM	MIM + Machining
Application	DCT	DCT	E-Car	Electronic Parking Brake	Electronic Parking Brake

Photo					
Part	SLEEVE CENTER BOLT	ENDCAP	SPOOL	Lens holder	Sector Gear
Material	AISI4140	Fe2%	Fe2%	SUS316	Confidential
Process	MIM + Machining	MIM	MIM + Machining	MIM + Machining	MIM + Machining
Application	OPPS	Rack type Electric Power Steering	Suspension	Camera Module	E-Parking

APPLICATION

Photo					
Part	Vane	Vane Lever	2K Lever	2K Pin	Steering Rod
Material	HK30	HK30	HK30 + Co Base	Stellite + SUS316L	HK30
Process	MIM + Machining	MIM + Machining	MIM + Machining	MIM	MIM + Machining
Application	Turbo Charger	Turbo Charger	Turbo Charger	Turbo Charger	Turbo Charger

Photo					
Part	Turbine Wheel	Top Plate	Weight	Guide Drum	Micro Hinge
Material	Titanium	SUS420J2	Tungsten	SUS440C	SUS420J2
Process	MIM + Machining	MIM	MIM	MIM	MIM
Application	Turbo Charger	Smart Watch	Mobile	Electronics	Mobile

APPLICATION

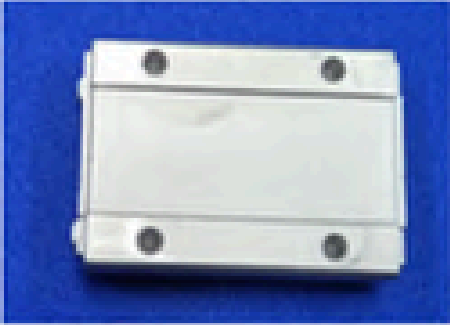
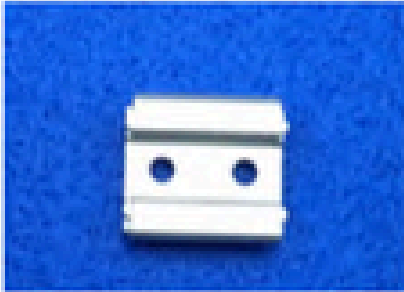
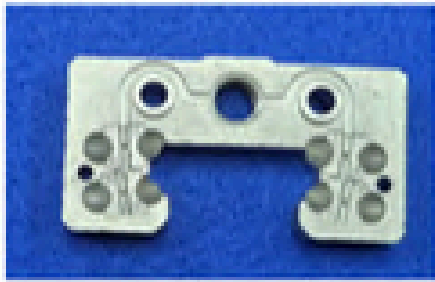

Photo				
Part	LM GUIDE	LM GUIDE	End Plate	Machining Tool
Material	SUS440C	SUS440C	SUS304 L	Tungsten
Process	MIM	MIM	MIM	MIM + Machining
Application	Automation	Automation	Automation	Automation

Photo				
Part	Guide Bushing	Handpiece Head	Ball Mark	Machining Tool
Material	Titanium	SUS316 L	SUS630	Tungsten
Process	MIM	MIM	MIM	MIM + Machining
Application	Medical	Medical	Sport(Golf)	Automation

ENGINEERING DIVISION



PRODUCTS

SPECIAL PURPOSE MACHINE

MOLD & DIES

PRECISION PARTS

INSPECTION JIG

MACHINERY

MACHINERY FACILITY

MACHINE	Qty	MACHINE	Qty
Lathe Machine	67	Welding Machine	70
Lathe Machine CNC	9	Bending Machine	9
Milling Machine	43	Bending Machine CNC	4
Milling Machine CNC	30	Cutting Machine	4
Shaper Machine	4	Cutting Edges	2
Drilling Machine	15	Punching Machine	18
Grinding Machine	49	Punching Machine CNC	3
Gear Hobbing, Wire Cut, EDM, Jig Boring	15	Oven	9
Injection Machine	10	Powder Coating Painting Device	3
Die Casting	1	Welding Machine	70

Sawing:

- AMADA 416.09.1 Conventional Band Saw 1
- KASTO 416.02.1 Conventional Bench Saw
- SCHMID 416.03.1 Conventional Bench Saw
- KRISBOW Conventional Band Saw

Turning:

- OERLIKON 408.11.1 Conventional Horizontal Turning
- HAMATU 408.24.1 Conventional Horizontal Turning
- GALLIC 16 PAP 408.09 Conventional Horizontal Turning
- TAKISHAWA 408.25.1 Conventional Horizontal Turning
- GEDEE WEILER CNC Horizontal Turning
- FEDEK 408.110.1 CNC Horizontal Turning with Bar Feeder



Milling:

- SCHAUBLIN 409.02.1 Conventional Milling
- BEIJING 409.13.2 Conventional Milling
- STARRAG 409.102.1 CNC 3-Axes Milling
- MAHO 409.101.7 CNC 3-Axes Milling
- VICTOR 409.103.1 CNC 3-Axes Milling
- YCM 409.117.2 CNC 3+1-Axes Milling

Grinding:

- KELLENBERGER 406.03.3 Universal Grinding Machine
- KELLENBERGER 406.03.2 Universal Grinding Machine
- KELLENBERGER 406.03.1 Universal Grinding Machine



Drilling:

- SORALUCE 403.02.2 Radial Drilling Machine
- GILLARDON 403.12.1 Column Drilling Machine
- ACIERA 403.07.1 Bench Drilling and Tapping

QC and Measuring:

- MICRO HITE U.MT.MH600.TS.1 Digital Height Gauge
- MITUTOYO STRATO IA-2614107 Coordinate Measuring Machine (CMM)



Special Purpose Machine:

1. Automotive
2. Consumer Goods

Automotive Experience:

- PT. Showa Indonesia Manufacturing
- PT. Keihin Indonesia
- PT. Yutaka Manufacturing Indonesia
- PT. Sakura Java Indonesia
- PT. Yamaha Part Manufacturing Indonesia

Consumer Goods Experience:

- PT. Unilever Indonesia
- PT. Nutricia Indonesia
- PT. Indolakto Indonesia
- PT. Yasulor Indonesia
- PT. Sari Husada



Mold & Dies:

1. Automotive

Mold - Die Cast Experience:

- PT. Yasufuku Indonesia
- PT. Mitra Makmur Gemilang
- PT. Chemco Harapan Nusantara
- PT. Tri Dharma Wisesa
- PT. Cabinindo Indonesia

Stamping Dies Experience:

- PT. Nusa Toyotetsu Indonesia
- PT. Indomobil Indonesia (2W)
- PT. Muramoto Elektronik Indonesia

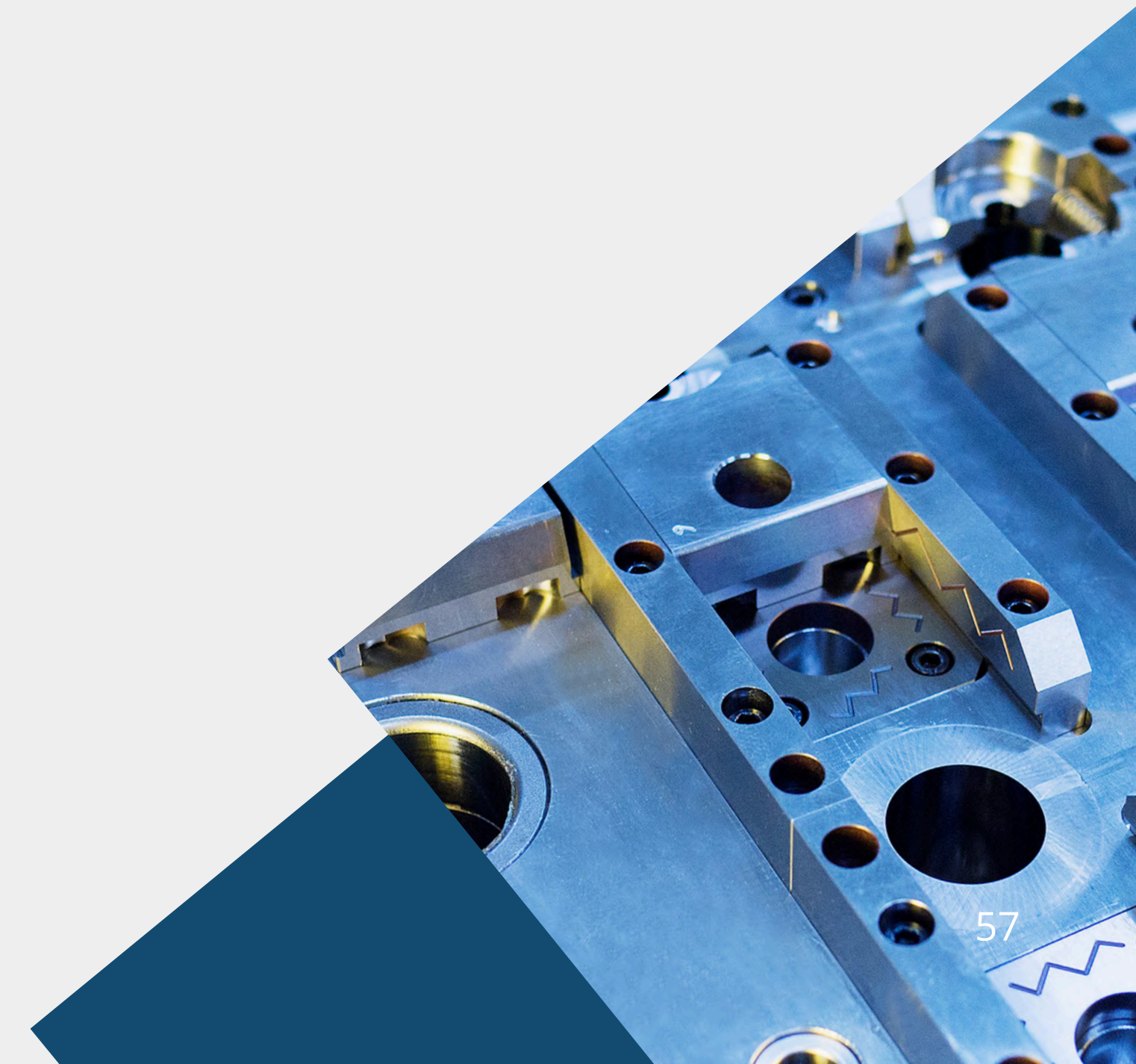

Our Team Experience:

- PT. Astra Honda Motor
- PT. Yamaha Parts Manufacturing Indonesia
- PT. Bekaert Indonesia
- PT. Unilever Indonesia
- PT. Panasonic Manufacturing Indonesia
- PT. Denso Indonesia



Our Team Experience:

- PT. Yutaka Manufacturing Indonesia
- PT. Komatsu Indonesia
- PT. Sakura Java Indonesia
- PT. Gaya Motor Indonesia
- PT. Yamaha Motor Electric Indonesia



VMC 60 E | CNC Milling Machine



Specifications		
Table Size	mm	1000 x 320
T-slot (N/W/D)	mm	3 / 14 /105
Max table loading weight	kg	400
X/Y/Z	mm	650 / 400 / 500
Spindle speed range	rpm	8000
Spindler taper		BT40
X/Y/Z rapid feed speed	m/min	24 / 24 /20
Spindle nose to worktable distance	mm	120 - 260
Spindle center to column distance	mm	440
Spindle motor power	kW	5.5
Magazine capacity		12
Tool magazine type		Disk
Positioning accuracy		0.008
Repeatability	mm	0.05 / 300
Net weight	kg	3200

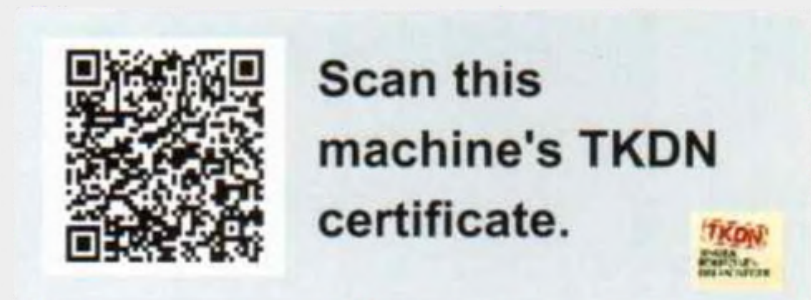

TKDN 43.00%

Standard Accessories

SIEMENS 808D controller, 12-position tool magazine, MPG hand wheel, LED working light, Full-protection cover, Chip tray, Instruction manual books

LEANTURN LT 300-100 | CNC Lathe Machine



Capacity

Swing over (z Axiz Cover) dia	: 380 mm
Swing over cross slide dia	: 120 mm
Max turning dia	: 100 mm
Max bar capacity	: 25 dia

Spindle

Spindle nose DIN 55026	: 380 mm
Spindle Speed	: 120 mm
Spindle through bore dia	: 100 mm

Working Holding

Chuck type	: Manual Chuck
Chuck size	: 130 dia
X axis travel	: 200 mm
Z axiz travel	: 280 mm

Feed Rate

Rapid traverse X axis	: 20 m/min
Rapid traverse Z axis	: 25 m/min

Tooling

Tooling arrangement	: TURRET BTP 50
Tooling size	: dia 16 x 16 mm
Boring bar size	: 25 mm

Machine Size

Machine height	: 1540 mm
Floor space	: 1500 x 1500 mm
Machine weight	: 1300 kg

Accessories

Coolant supply equipment
Centralized lubrication equipment
Chip trolley
Work light

TKDN 42.49%



PT. ALMIK KURNIA BERSAMA

 www.ptalmik.com

 ptalmik@gmail.com
marketing@ptalmik.com

 (021) - 886 55 03

 Grha LN Bekasi Bagus Jl. KH. Noer
Ali No. 89 Kalimalang, Bekasi 17144

